



TENDER DOCUMENT

FOR

**DESIGN, SUPPLY, ERECTION AND COMMISSIONING OF
AMORPHOUS ELECTRICAL STEEL (AES) PRODUCTION PILOT PLANT**

**COUNCIL OF SCIENTIFIC AND INDUSTRIAL RESEARCH
NATIONAL METALLURGICAL LABORATORY
BURMAMINES, JAMSHEDPUR – 831007 JHARKHAND -
INDIA**



Council of Scientific and Industrial Research
National Metallurgical Laboratory
Burmamines, Jamshedpur – 831007, Jharkhand-India
Tel #: 00 91 657 2345129/32
Email: spo@nmlindia.org
Website: www.nmlindia.org

Invitation for Bids / Notice Inviting E-Tender

CSIR- National Metallurgical Laboratory (NML), Jamshedpur, India is one of the premier laboratories under Council of Scientific and Industrial Research, an autonomous body under Department of Scientific and Industrial Research (Government of India), New Delhi. CSIR-NML is a Science and Knowledge based Research, Development and Consulting Organization. It is internationally known for its excellence in Scientific Research in Metallurgical Engineering.

The Director, CSIR-NML invites sealed bids from their Manufacturers, their distributors and Indian Agent of Foreign Principals, if any, for the procurement of the following Goods/Services for its day-to-day research. The Technical specifications, Allied requirements and scope of supply are given in **Chapter 4** appended herewith.

Sl. No.	Tender No.	Brief Description of item(s)	Unit	Quantity	Single / Two Bid
1	NML-3(O2/AMP/AKP)/18-PS(15)	PART-A: Detailed design, Supply, Erection and commissioning of the Pilot plant equipment along with all accessories and utilities.	Set	1	Two
		PART-B: Design, supply, Erection of Pre-Engineered Industrial Building (PEB) to house the Pilot Plant equipment and other utilities and facilities.	Set	1	
		PART-C: Design, Supply, Erection and commissioning of 5T EOT crane for the above said Pilot Plant.	Set	1	

1. E-Bids are invited through the electronic tendering process and the Tender Document can be downloaded from the e-Tender Central Public Procurement Portal (CPPP) of Government of India, <https://etenders.gov.in>. A copy of the Tender Document is also available on CSIR-NMLWebsite, www.nmlindia.org **The submission of e-Bids will be only through the e-Tender portal <https://etenders.gov.in>. Bids will not be accepted in any other form.**
2. The address for submission of EMD/Bid Security and for obtaining further information:
Stores & Purchase Officer
Purchase Section
National Metallurgical Laboratory
Burmamines, Jamshedpur – 831007, Jharkhand-India
Tel #: 00 91 657 2345129/32
Email: spo@nmlindia.org

The prospective bidders should adhere to deadlines specified in Tender Details Screen corresponding to this Tender on E-Tender portal <https://etenders.gov.in>.

3. A Pre-Bid Conference will be held on schedule mentioned below. All prospective bidders are requested to kindly submit their queries to the address indicated above so as to reach the Stores & Purchase Officer at least one day before Pre-Bid Conference.

The changes, if any, made in the Tender Document after Pre- Bid Conference would be treated as amendment to the Tender Document and the same would be hosted on e-tenders portal as Corrigendum to enable all the bidders to take note of the amendments. Specifications finalized after Pre- bid conference would not be changed further and would be basis of evaluation and consequently there shall be no occasion for revision of technical/ price bid.

Bidders may submit their bids only after the Pre- Bid Conference so as to take care of the changes, if any, made in the Tender Document.

Pre-Bid Conference	Date	Time in hours (IST)	Venue
Date , Time & Venue of Pre-Bid conference	22.06.2018	11 AM	Old Conference Room
Date of publishing revised NIT	30.06.2018		

4. The Bid prepared by the Bidder shall include the following: -

Bid Security (BS) / Earnest Money Deposit (EMD)		
a)	In case of Foreign Bidder	In case of Indigenous Bidder
	US\$ 53731/- [US\$ Fifty Three Thousand Seven Hundred and Thirty One Only] Euro 46153/- [Euro Forty Six Thousand One Hundred and Fifty Three Only]	Rs. 3600000/- [Rupees Thirty Six Lakhs Only]
b)	The Bid Security/Earnest Money Deposit shall be deposited through Bank Guarantee/Demand Draft drawn in favour of "The Director, National Metallurgical Laboratory, Jamshedpur" . The original Bid Security/EMD must be delivered to address mentioned in Sr.No.2 above on or before bid submission date and time as mentioned in "Date Sheet" failing which the bid shall be summarily rejected. For further details, refer Clause No.1.15 of Tender document.	
c)	Form as specified in Chapter No.8	

5. The Director, CSIR- National Metallurgical Laboratory (NML), Jamshedpur, India reserves the right to accept or reject any or all tenders / offers either in part or in full or to annul the tender process at any stage or to split the order without assigning any reasons there for.

SCHEDULE CUM CRITICAL DATE SHEET

1	Name of Organization	CSIR-National Metallurgical Laboratories, Jamshedpur
2	Tender Reference No	NML-3(O2/AMP/AKP)/18-PS(15)
3	Tender Type (Open/Limited/EOI/Auction/Single)	Open
4	Type/Form of Contract (Work/Supply/Auction/Service/Buy/Empanelment/Sell)	Supply
5	No of Covers (One/Two/Three/Four)	Two
6	Tender Category (Services/Goods/Works)	Goods
7	Allow Resubmission (Only in online mode within scheduled period)	Yes
8	Allow Withdrawal (Only in online mode within scheduled period)	Yes
9	Allow Offline Submission	No
10	Supply Title	<p>PART-A: Detailed design, Supply, Erection and commissioning of the Pilot plant equipment along with all accessories and utilities.</p> <p>PART-B: Design, supply, Erection of Pre-Engineered Industrial Building (PEB) to house the Pilot Plant equipment and other utilities and facilities.</p> <p>PART-C: Design, Supply, Erection and commissioning of 5T EOT crane for the above said Pilot Plant</p>
11	Supply Description	<p>PART-A: Detailed design, Supply, Erection and commissioning of the Pilot plant equipment along with all accessories and utilities.</p> <p>PART-B: Design, supply, Erection of Pre-Engineered Industrial Building (PEB) to house the Pilot Plant equipment and other utilities and facilities.</p> <p>PART-C: Design, Supply, Erection and commissioning of 5T EOT crane for the above said Pilot Plant</p> <p>Details as per Chapter-4</p>
12	Product Category (Civil Works/Electrical Works/Fleet Management/Computer Systems)	R & D Equipment
13	Is Multi Currency Allowed	Yes
14	a) Tender Publishing Date & Time	12.06.2018 17.00 Hrs
	b) Document Download Start Date & Time	13.06.2018 09.00 Hrs
	c) Seek Clarification Start Date & Time	14.06.2018 09.00 Hrs.
	d) Seek Clarification End Date & Time	21.06.2018 17.00Hrs.
	e) Pre-Bid Conference Date & Time	22.06.2018 11.00 Hrs
	f) Bid Submission Start Date & Time	01.07.2018 09.00 Hrs
	g) Bid Submission End Date & Time	23.07.2018 14.00 Hrs
	h) Bid Opening Date & Time	24.07.2018 15.00 Hrs

15	Bid Validity Days	180 days from the date of Opening of the Technical Bid prescribed by the Purchaser
16	Address for communication	The Stores & Purchase Officer, CSIR-National Metallurgical Laboratory Burmamines, Jamshedpur – 831007, Jharkhand-India Tel #: 00 91 657 2345129/32 Email: spo@nmlindia.org
17	Inviting Officer	The Director, CSIR-NML
18	Contact No	2345129/32
19	E-mail Address	spo@nmlindia.org
20	Details specification of the Goods/Services	Refer Chapter-4

General Instructions to Bidders:-

01. Tender Documents May be downloaded from Central Public Procurement Portal <https://www.etenders.gov.in>. Aspiring Bidders who have not enrolled/ registered in e- procurement should enroll/ register before participating through the website <https://www.etenders.gov.in>. The portal enrolment is free of cost. Bidders are advised to go through instructions provided at 'Instructions for online Bid Submission'.
02. Tenderers can access tender documents on the website (For searching in the NIC site <https://www.etenders.gov.in>, select tender type and select 'Council of Scientific and Industrial Research' in organization tab and select 'NML-Jamshedpur-CSIR' in department type Thereafter, Click on "Search" button to view all CSIR-NML, Jamshedpur tenders). Select the appropriate tender and fill them with all relevant information and submit the completed tender document online on the website <https://www/etenders.gov.in> as per the schedule given in the next page.
03. All bidders are advised to check the LATEST CORRIGENDUM LIST in the "Tender Details" and take note of all the corrigenda issued with respect to the Tender.

Stores and Purchase Officer

CONTENTS OF TENDER / BIDDING DOCUMENT

The bidding documents, apart from the Invitation for Bids / Notice Inviting Tender have been divided into Eight (8) Chapters as under:

Chapter No.	Name of the Chapter	Page No.
1	Instructions to Bidder (ITB)	9 -23
2A	General Conditions of Contract (GCC)	24-36
2B	Special Conditions of Contract (SCC)	37-42
3	Schedule of Requirements	43
4	Specifications, Allied Technical Details And Scope of Supply	44 - 76
5	Qualification requirements	77
6	Price Schedule Forms	78 - 84
7	Contract Form	85
8	Standard Forms	86 - 103

LIST OF SHORT FORMS AND FULL FORMS

ACRONYM	EXPANSION
BG	BANK GUARANTEE
BS	BID SECURITY
CIF	COST INSURANCE FREIGHT
CIP	CARRIAGE PAID TO
CSIR	COUNCIL OF SCIENTIFIC AND INDUSTRIAL RESEARCH
CVC	CHIEF VIGILANCE COMMISSION
DGS&D	DIRECTOR GENERAL OF SUPPLIES & DISPOSAL
EMD	EARNEST MONEY DEPOSIT
ESIC	EMPLOYEES STATE INSURANCE CORPORATION
FCA	FREE CARRIAGE ALONG SIDE
FOB	FREE ON BOARD
GCC	GENERAL CONDITIONS OF CONTRACT
GOI	GOVERNMENT OF INDIA
GST	GOODS & SERVICES TAX
IT	INCOME TAX
ICC	INTERNATIONAL CHAMBERS OF COMMERCE
IEMs	INDEPENDENT EXTERNAL MONITORS
IP	INTEGRITY PACT
IPC	INDIAN PENAL CODE
IST	INDIAN STANDARD TIME
ITB	INSTRUCTION TO BIDDER
JS (A)	JOINT SECRETARY (ADMINISTRATION)
LC	LETTER OF CREDIT
LC	LETTER OF CREDIT
LD	LIQUIDATED DAMAGES
NML	NATIONAL METALLURGICAL LABORATORIES
NIT	NOTICE INVITING TENDER
NSIC	NATIONAL SMALL INDUSTRIES CORPORATION
PS	PERFORMANCE SECURITY
SCC	SPECIAL CONDITIONS OF CONTRACT
UNCITRAL	UNITED NATIONS COMMISSION ON INTERNATIONAL TRADE

CHAPTER 1 - INSTRUCTIONS TO BIDDERS - Table of Contents

Clause No.	Contents	Page No.
A. Introduction		
1.0	Definition of Turnkey for this Document	9
1.1	Eligible Bidders	9
1.2	Cost of Bidding	9
1.3	Fraud and Corruption	9
B. The Bidding Documents		
1.4	Cost of Bidding Documents	9
1.5	Content of Bidding Documents	9
1.6	Clarification of Bidding Documents	10
1.7	Amendment to Bidding Documents	10
C. Preparation of Bids		
1.8	Language of Bid	11
1.9	Documents Comprising the Bid	11
1.10	Bid form and price schedule	12
1.11	Bid Prices	12
1.12	Bid Currencies	13
1.13	Documents establishing Bidder's Eligibility and Qualifications	13
1.14	Documents establishing Goods' Eligibility and Conformity to Bidding Documents	13
1.15	Bid Security / Earnest Money Deposit	14
1.16	Period of Validity of Bids	15
1.17	Format and Signing of Bid	15
D. Submission and Sealing of Bids		
1.18	Submission, Sealing and Marking of Bids	16
1.19	Due date for Submission of Bids	16
1.20	Late Bids	16
1.21	Withdrawal, Substitution and Modification of Bids	17
E. Opening and Evaluation of Bids		
1.22	Opening of Bids by the Purchaser	16
1.23	Confidentiality	17
1.24	Clarification of Bids	17
1.25	Preliminary Examination	17
1.26	Responsiveness of Bids	18
1.27	Non-Conformity, Error and Omission	18
1.28	Examination of Terms & Conditions, Technical Evaluation	19
1.29	Conversion of Single Currency	19
1.30	Evaluation and Comparison of Bids	19
1.31	Comparison of Bids	20
1.32	Contacting the Purchaser	20
1.33	Post qualification	20
F. Award of Contract		
1.34	Negotiations	21
1.35	Award Criteria	21
1.36	Purchaser's right to vary Quantities and Time of Award or later	21
1.37	Purchaser's right to accept any Bid and to reject any or all Bids	21
1.38	Notification of Award	21
1.39	Signing of Contract	21
1.40	Order Acceptance	21
1.41	Performance Security	21
1.42	Assistance to Bidders	21
1.43	Quality Assurance Plan	22-23

A. Introduction

Instructions to bidder are broad guidelines to be followed while formulating the bid and its submission to the Purchaser. It also describes the methodology for opening and evaluation of bids and consequent award of contract.

1.0 Definition of Turnkey for this Document

Turnkey would be defined in this document as -

It is a contract under which a firm undertakes the entire responsibility to fully design, construct and equip a manufacturing / service facility and turn the project over to the purchaser when it is ready for operation.

1.1 Eligible Bidders

1.1.1. This Invitation for Bids is open to all suppliers.

1.1.2. Bidders should not be associated, or have been associated in the past, directly or indirectly, with a firm or any of its affiliates which have been engaged by the Purchaser to provide consulting services for the preparation of the design, specifications, and other documents to be used for the procurement of the goods to be purchased under this Invitation of Bids.+

1.1.3. Bidders who fulfil the Eligibility Criteria mentioned in **Chapter 5** will be considered for Technical Evaluation of bids.

1.1.4. (a.) The bidder should have experience in developing / producing amorphous/ nanocrystalline wide ribbons at a scale of minimum 100kg batch

or

The bidder must have technology alliance with other entity having experience in developing / producing amorphous / nanocrystalline wide ribbons at a scale of minimum 100kg batch.

(b.) Financial capability: Minimum turnover of Rupees 50 crores per annum. The bidder shall furnish Bankers' certificate, Balance sheet, Income tax returns etc., documentary evidence of all the pre-qualification criteria indicated in (a) and(b).

1.2 Cost of Bidding

The Bidder shall bear all costs associated with the preparation and submission of its bid, and "the Purchaser", will in no case be responsible or liable for these costs, regardless of the conduct or outcome of the bidding process.

1.3 Fraud and corruption

1.3.1. The purchaser requires that the bidders, suppliers and contractors observe the highest standard of ethics during the procurement and execution of such contracts. In pursuit of this policy, the following are defined:

Sr. No.	Term	Meaning
(a)	Corrupt practice	The offering, giving, receiving, or soliciting, directly or indirectly, of anything of value to influence the action of a public official in the procurement process or in contract execution.
(b)	Fraudulent practice	a misrepresentation or omission of facts in order to influence a procurement process or the execution of a contract.
(c)	Collusive practice	means a scheme or arrangement between two or more bidders, with or without the knowledge of the purchaser, designed to establish bid prices at artificial, non-competitive levels.
(d)	Coercive practice	means harming or threatening to harm, directly or indirectly, persons or their property to influence their participation in the procurement process or affect the execution of a contract.

1.3.2. The Purchaser will reject a proposal for award if it determines that the Bidder recommended for award has, directly or through an agent, engaged in corrupt, fraudulent, collusive or coercive practices in competing for the Contract in question.

B. The Bidding Documents

1.4 Cost of Bidding Documents

The bidding documents are to be **downloaded Free of Cost** from CPPP Website <https://etenders.gov.in>

1.5 Content of Bidding Documents

- 1.5.1. The Goods / Services required, bidding procedures and contract terms are prescribed in the bidding documents which should be read in conjunction. The bidding documents, apart from the Invitation for Bids / Notice Inviting Tender have been divided into Eight Chapters.
- 1.5.2. The Bidder is expected to examine all instructions, forms, terms, and specifications in the bidding documents. Failure to furnish all information required by the bidding documents or submission of a bid not substantially responsive to the bidding documents in every respect will be at the Bidder's risk and may result in rejection of its bid.

1.6 Clarification of bidding documents

1.6.1. In case when there is NO PRE-BID CONFERENCE

A prospective Bidder requiring any clarification of the Bidding Documents shall contact the Purchaser in writing at the Purchaser's address specified in the Special Conditions of Contract (SCC), latest by the Purchaser will respond in writing through e-mail to any request for clarification, provided that such request is received not later **than ten (10) days** prior to the due date for submission of bids. Should the Purchaser deem it necessary to amend the Bidding Documents as a result of a clarification, it shall do so following the procedure under *Clause 1.7* relating to amendment of bidding documents and *Clause 1.19* relating to Due date for Submission of Bids. The amendments issued would be hosted on the CPPP website <https://etenders.gov.in> of the purchaser for the benefit of the prospective bidders who are expected to take cognizance of the same before formulating and submitting their bids.

1.6.2. In case when there is PRE-BID CONFERENCE

- a) A prospective Bidder requiring any clarification of the Bidding Documents shall contact the Purchaser in writing at the Purchaser's address specified in the Special Conditions of Contract (SCC), latest by the date specified in the Invitation for Bids / NIT which would be deliberated as per **Clause 1.6.2 (b)** of Instructions to the Bidders. No request for clarification or query shall be normally entertained after the **Pre-Bid Conference**. Should the Purchaser deem it necessary to amend the Bidding Documents as a result of a clarification, it shall do so following the procedure under *Clause 1.7* relating to amendment of Bidding Documents and *Clause 1.19* relating to Due Date for Submission of Bids. The clarifications and amendments issued would also be hosted on the CPPP website <https://etenders.gov.in> of the Purchaser for the benefit of the other prospective bidders.
- b) A Pre-bid Conference shall be held as indicated in Invitation to Bid. All prospective bidders are requested to kindly attend the Pre-bid Conference. In order to facilitate CSIR-NML for proper conduct of the Pre-bid Conference, all prospective bidders are requested to kindly submit their queries (with envelope bearing Tender No. and Date on top and marked "Queries for Pre-bid Conference") so as to reach CSIR-NML as indicated in Invitation to Bid. Queries may be sent by email to spo@nmlindia.org. CSIR-NML shall answer the queries during the pre-bid conference, which would become a part of the proceedings of the Pre-bid Conference. These proceedings will become a part of clarifications / amendments to the bidding documents and would become binding on all the prospective bidders. These proceedings would also be hosted on CPPP website <https://etenders.gov.in> for the benefit of all the prospective bidders. Before formulating and submitting their bids, all prospective bidders are advised to surf through the CPPP website <https://etenders.gov.in> after the Pre-bid Conference, in order to enable them take cognizance of the changes made in the bidding document.

1.7 Amendment to Bidding Documents

- 1.7.1. At any time prior to the due date for submission of bids, the Purchaser may, for any reason, whether at its own initiative or in response to a clarification requested by a prospective bidder, modify the bidding documents by amendment.
- 1.7.2. All prospective bidders who have downloaded the Tender Document should surf CPPP website <https://etenders.gov.in> from time to time to know about the changes / modifications in the Tender Document. The changes / modifications would also be hosted on the CPPP website <https://etenders.gov.in>. All prospective bidders are expected to surf the CPPP website <https://etenders.gov.in> before formulating and submitting their bids to take cognizance of the amendments.

All bidders are advised to check the LATEST CORRIGENDUM LIST in the "Tender Details" and take note

of all the corrigenda issued with respect to the Tender.

- 1.7.3. In order to allow prospective bidders reasonable time to take the amendment into account while formulating their bids, the Purchaser, at its discretion, may extend the due date for the submission of bids and host the changes on the CPPP website <https://etenders.gov.in> of the purchaser.

C. Preparation of bids

1.8 Language of Bid

- 1.8.1. The bid prepared by the Bidder, as well as all correspondence and documents relating to the bid exchanged by the Bidder and the Purchaser, shall be written in English language only especially when the details are technical. However, if GOI makes it mandatory under Rajbhasha Adhinyam, in that case views of Rajbhasha unit of CSIR may be sought.
- 1.8.2. The Supplier shall bear all costs of translation, if any, to the English language and bear all risks of the accuracy of such translation, for documents provided by the Supplier.

1.9 Documents Comprising the E-Bid

- 1.9.1. The E-bid shall comprise of the following documents as per the requirement of the Tender Document. The documents should be scanned and **uploaded in PDF format**.

Sr. No.	Document Required	Reference Clause & Forms of tender document
1	Bid Security / EMD for amount specified in NIT	1.15 & Chapter-8: Annexure-C
2	Bidder Information Form	Chapter-8: Annexure-A
3	Certificate of Incorporation	5.1 (a)
4	Manufacturers Authorisation Form	Chapter-8: Annexure-B
5	Agency Agreement / MOU	5.1 (b)
6	Eligibility Certificate	5.1 (c)&Chapter-8: Annexure-K
7	Self-Certificate: Non-Black Listing	5.1 (d) &Chapter-8: Annexure-L
8	Performance Statement Form	5.2 (b) &Chapter-8: Annexure-D
9	Service Support Details	5.2 (c) &Chapter-8: Annexure-F
10	Creditworthy Report (if applicable)	5.3
11	Detailed Technical Specifications & Scope of Supply	Chapter-4
12	Schedule of Requirement	Chapter-3
13	Deviation Statement	Chapter-8: Annexure-E (Part-I & II)
14	Bid Form	Chapter-8: Annexure-G
15	Price Schedule Form (s)	Chapter-6

The documents comprising bid should be submitted in the **above sequence in orderly manner**. **Bid is Single Bid or Two Bid is specified in NIT.**

1.9.2 Documents comprising Single Bid

All the above documents should be submitted in Single E-Bid.

1.9.3 Documents comprising Two Bid (Technical Bid & Price Bid)

- (a) Bidding shall be done in two bid system- Technical Bid and Price Bid.
- (b) **Technical bid** should comprise of documents listed from Sr.No.1 to 13 and Bid Form & Price Schedule Form **without mentioning** prices and discount. It should also include-
- I. Bankers' Certificate.
 - II. Balance Sheet of last 3 Financial years.
 - III. Income Tax Returns of last 3 Financial years.
 - IV. All applicable Technical brochures from OEM.
 - V. Warranty documents.
 - VI. List of mandatory spares and also 2 years running spares.
- (c) Price Bid shall comprise of the prices as per Table 2.21.1 including-
- (i) Pricing of Item no: Part A, Part B, Part C & Mandatory Spares (As per Chapter 6A and Chapter 6B) .
 - (ii) The cost of 2 years running spares as per Chapter 6A(iii) and Chapter 6B(iii).
 - (iii) Cost of first three years extended warranty (quoted separately for each year) as per Chapter 6A(iii) and Chapter 6B(iii).

1.10 Bid form and Price Schedule

The bidder shall complete the Bid Form and the appropriate Price Schedule form as given in Chapter-6 furnished in the bidding documents. These forms must be completed without any alterations to its format and no substitutes shall be accepted. All blank spaces shall be filled in with the information requested. The Bid Form and the appropriate Price Schedule form shall be submitted in accordance with **ITB Clauses 1.9.2 & 1.9.3** of the bidding documents.

1.11 Bid Prices

1.11.1. The Bidder shall indicate on the appropriate price schedule form, the unit prices and total bid prices of the Goods / Services it proposes to supply under the contract.

1.11.2. Prices indicated on the price-schedule form shall be entered separately in the following manner:

(a) For Goods manufactured within India:

i)	The price of the goods quoted Ex-works
ii)	GST which will be payable on the goods if the contract is awarded.
iii)	The charges for inland transportation, insurance and other local services required for delivering the goods at the desired destination as specified in the price schedule form.
iv)	The installation, commissioning and training charges including any incidental services, if any.

(b) For Goods manufactured abroad:

i)	The price of the goods, quoted on FCA (named Airport abroad) or FOB (named port of shipment), as specified in the price schedule form.
ii)	The charges for insurance and transportation of the goods to the port / place of destination.
iii)	The agency commission charges payable to Indian agent in Indian rupees, if any.
iv)	The installation, commissioning and training charges including any incidental services, if any

1.11.3. The terms FOB, FCA, CIF, CIP etc. shall be governed by the rules prescribed in the current edition of the Incoterms published by the International Chambers of Commerce, Paris.

1.11.4. **Where there is no mention of packing, forwarding, freight, insurance charges, taxes, any charges mentioned as extras as applicable etc.; or tax at your account or tax to be borne by the Buyer, such offer may be rejected as incomplete.**

1.11.5. The price quoted shall remain fixed during the contract period and shall not vary on any account.

1.11.6. All lots and items must be listed and priced separately in the Price Schedules. If a Price Schedule shows items listed but not priced, their prices shall be assumed to be included in the prices of other items. Lots or items not listed in the Price Schedule shall be assumed to be not included in the bid.

- 1.11.7. The CSIR-NML is a public funded Research Institution under Department of Scientific & Industrial Research and concessional Custom Duty @5.15% is applicable for the goods purchased for research purpose vide Government of India Notification No.51/96-Customs dated 23.07.1996
- 1.11.8. In case of imports the freight & insurance will be paid by the Purchaser, as the consignments are to be shipped through the Purchaser nominated freight forwarder.
- 1.11.9. The quotation should be only in Indian Rupees for indigenous items. In case of foreign quote, the vendors may quote their rates in Indian Rupees as well as in Foreign Currency.
- 1.11.10. In case of INR bids the price criteria should be on Free Delivery to CSIR-NML, Jamshedpur. Govt. Levies like GST etc., if any, shall be paid at actual rates applicable on the date of delivery. Rates should be quoted accordingly giving the basic price, GST etc., if any.
- 1.11.11. Custom Duty is levied on all import meant for CSIR-NML. Hence, the suppliers are requested to quote only on FOB/FCA basis, freight, insurance and custom duty as applicable to R&D Institutions will be paid by the Purchaser.
- 1.11.12. CSIR-NML is a public funded Research Institution under Department of Scientific & Industrial Research and concessional GST (IGST@5% OR SGST @ 2.5% and CGST@2.5%) shall be made applicable for the goods purchased for research purpose vide Ministry of Finance (Department of Revenue) Notification No.47/2017-Integrated Tax dated 14.11.2017 & Notification No.45/2017- Central Tax dated 14.11.2017 in due course of time. Till such time GST as applicable shall be paid.

Note: All payments due under the contract shall be paid after deduction of statutory levies at source (like ESIC, IT, etc.), wherever applicable.

1.12 Bid Currencies

Prices shall be quoted in Indian Rupees for offers received for supply within India and in freely Convertible foreign currency in case of offers received for supply from foreign countries.

1.13 Documents Establishing Bidder's Eligibility and qualifications

- 1.13.1. The bidder shall furnish, as part of its bid, documents establishing the bidders' eligibility to bid and its qualification to perform the contract if its bid is accepted.
- 1.13.2. The documentary evidence of the bidders qualification to perform the contract if the bid is accepted shall establish to the purchasers satisfaction that:

(a)	The bidder meets the qualification criteria listed in bidding documents, if any.
(b)	Bidder who doesn't manufacture the goods it offers to supply shall submit Manufacturers' Authorization Form using the form specified in the bidding document to demonstrate that it has been duly authorized by the manufacturer of the goods to quote and / or supply the goods.
(c)	In case a bidder not doing business within India, it shall furnish the certificate to the effect that the bidder is or will be represented by an agent in India, equipped and able to carry out the supply, maintenance, repair obligations etc. during the warranty and post warranty period or ensure a mechanism at place for carrying out the supply, maintenance, repair obligations etc. during the warranty and post-warranty period.

- 1.13.3. Conditional tenders / offers shall **not** be accepted.

1.14 Documents Establishing Goods' Eligibility and Conformity to Bidding Documents

- 1.14.1. To establish the goods' eligibility, the documentary evidence of the goods and services eligibility shall consist of a statement on the country of origin of the goods and services offered which shall be confirmed by a certificate of origin at the time of shipment.
- 1.14.2. To establish the conformity of the goods and services to the specifications and schedule of requirements of the bidding document, the documentary evidence of conformity of the goods and services to the bidding documents may be in the form of literature, drawings and data, and shall consist of:

(a)	A detailed description of the essential technical and performance characteristics of the goods;
(b)	A list giving full particulars, including available sources and current prices, of spare parts, special tools, etc., necessary for the proper and continuing functioning of the goods during the warranty period following commencement of the use of the goods by the Purchaser in the Price- bid ; and
(c)	An item-by-item commentary on the Purchaser's Technical Specifications demonstrating substantial responsiveness of the goods and services to those specifications or a statement of deviations and exceptions to the provisions of the Technical Specifications.

1.14.3. For purposes of the commentary to be furnished pursuant to above, the Bidder shall note that standards for workmanship, material and equipment, designated by the Purchaser in its Technical Specifications are intended to be descriptive only and not restrictive. The Bidder may substitute these in its bid, provided that it demonstrates to the Purchaser's satisfaction that the substitutions ensure substantial equivalence to those designated in the Technical Specifications.

1.15 **Bid Security (BS) / Earnest Money Deposit (EMD)**

1.15.1. The Bidder shall furnish, as part of its bid, a Bid security (BS) / Earnest Money Deposit (EMD) of amount as specified in NIT in the form of a Bank Guarantee / Demand Draft drawn on any Nationalized Bank in favour of the Director, National Metallurgical Laboratory.

A. In case of Foreign Bidder(s):

a)	The BS shall be submitted either by the principal or by the Indian agent
b)	The bidder who submits the tender on behalf of their principals should produce documentary evidence in support of their authority to quote
c)	The Bank Guarantee is insisted due to steep fluctuations in foreign exchange hence the foreign DDs are not accepted towards BS/EMD

B. In the case of indigenous bidders:

a)	The BS shall be submitted by the manufacturer or their specifically authorized dealer/bidder
----	--

1.15.2. E-Bids submitted without BS/EMD will stand rejected. BS/EMD will not be accepted in the form of cash / cheque or any other form other than DD/Bank Guarantee as per format given in Chapter-8: **Annexure A**. No interest is payable on BS/EMD

1.15.3. The bid security is required to protect the Purchaser against the risk of Bidder's conduct, which would warrant the Bid security's forfeiture.

1.15.4. The bid security shall be in Indian Rupees for offers received for supply within India and denominated in the currency of the bid or in any freely convertible foreign exchange in the case of offers received for supplies from foreign countries in equivalent Indian Rupees. The bid security shall be in one of the following forms at the bidders' option:

(a)	A Bank Guarantee (BG) issued by a Nationalized Bank / Foreign Bank operating in India in the form provided in the bidding documents and valid for 45 days beyond the validity of the bid. In case a bidder desires to submit a BG issued from a foreign bank, then the same should be confirmed by a Nationalised / Scheduled Indian bank; OR
(b)	A Banker's cheque or demand draft in favour of the Purchaser issued by any Nationalised Bank.

1.15.5. The bid security shall be payable promptly upon written demand by the purchaser in case the conditions listed in the **ITB clause 1.15.11** are invoked.

1.15.6. The bid security should be submitted in its original form to the address:

Stores & Purchase Officer
Purchase Section
National Metallurgical Laboratory
Burmamines, Jamshedpur – 831007, Jharkhand-India
Tel #: 00 91 657 2345129/32
Email: spo@nmlindia.org

- 1.15.7. Scanned Copy of Demand Draft/Bank Guarantee towards bid security should be uploaded along with the E-bid.
- 1.15.8. Bid security / EMD is the mandatory requirement and exemption is applicable to the firms registered with NSIC only for the manufacture of the tendered goods and not for selling products manufactured by other companies.
- 1.15.9. The Bid Security of unsuccessful bidder will be discharged / returned as promptly as possible but positively within a period of 30 days after the expiration of the period of bid validity or placement of order whichever is later, without any interest.
- 1.15.10. The successful Bidder's bid security will be discharged upon the Bidder furnishing the Performance Security, without any interest. Alternatively, the BS could also be adjusted against Performance Security, if it is paid through Demand Draft / Banker's Cheque.
- 1.15.11. The receipt of Bid security before time and date of submission of bid is mandatory requirement. The bid is liable to be rejected if the bid security is not received within stipulated time.
- 1.15.12. The bid security may be forfeited:

(a)	If Bidder withdraws or amends or modifies or impairs or derogates its bid during the period of bid validity specified by the Bidder on the Bid Form; OR
(b)	In case of successful Bidder, if the Bidder fails to furnish order acceptance within 15 days of the order or fails to sign the contract and / or fails to furnish Performance Security within 21 days from the date of contract / order.
(c)	In case an unsuccessful Bidder quotes an unresponsive bid for the second time in a retendering , for example , does not agree to provide the Performance Bank Guarantee in his bid or does not conform to the payment terms as mentioned in the NIT and it is clear that the vendor is doing it purposefully, then based on the decision of The Director, CSIR-NML, the EMD of the firm may be forfeited.

- 1.15.13. Whenever the bidder chooses to submit the Bid Security in the form of Bank Guarantee, then he should advise the banker issuing the Bank Guarantee to immediately send by Registered Post (A.D.) an unstamped duplicate copy of the Guarantee directly to the Purchaser with a covering letter to compare with the original BG for the correctness, genuineness, etc.

1.16 Period of Validity of Bids

- 1.16.1. Bids shall remain valid for minimum of 180 days after the date of bid opening prescribed by the Purchaser. A bid valid for a shorter period shall be rejected by the Purchaser as non-responsive.
- 1.16.2. In exceptional circumstances, the Purchaser may solicit the Bidder's consent to an extension of the period of validity. The request and the responses thereto shall be made in writing (or by e-mail). The bid security provided shall also be suitably extended. A Bidder may refuse the request without forfeiting its bid security. A Bidder granting the request will not be required nor permitted to modify its bid.
- 1.16.3. Bid evaluation will be based on the bid prices without taking into consideration the above corrections.

1.17 Format and Signing of Bid

- 1.17.1. The bids may be submitted as Single-bid or Two-bid as specified in the Invitation for Bids / NIT.
- 1.17.2. In case the bids are invited on single bid basis, then the Bidder shall submit E-bid comprising all documents listed under clause 1.9 relating to documents comprising the bid.
- 1.17.3. In case the bids are invited on two-bid system, the Bidder shall submit E-bid in two separate parts. First part shall contain Technical bid comprising all documents listed under clause relating to Documents Comprising the Bid excepting bid form and price schedule forms. The second part shall contain the Price-Bid comprising Bid Form and Price Schedule forms.
- 1.17.4. The scanned copies of the E-bid shall be typed or written in indelible ink and shall be signed by the Bidder or a person or persons duly authorized to bind the Bidder to the Contract. All pages of the bid, except for un-amended printed literature, shall be initialled by the person or persons signing the bid.

- 1.17.5. Any interlineations, erasures or overwriting shall be valid only if they are initialled by the person or persons signing the bid.

D. Submission of E-Bids

1.18 Submission of E-Bids

- 1.18.1 Bids shall be submitted online only at CPPP website <https://etenders.gov.in>
Manual/ Offline bids shall not be accepted under any circumstances.
- 1.18.2 The Bidder shall download the Tender Enquiry Document directly from the website <https://etenders.gov.in> and shall not tamper/modify it in any manner. In case if the same is found to be tampered/modified in any manner, Tender/Bid will be summarily rejected and EMD would be forfeited.
- 1.18.3 The complete bidding process is online. Bidders should be in possession of valid Digital Signature Certificate (DSC) of class III for online submission of bids. Prior to bidding DSC need to be registered on the website mentioned above. If the envelope is not digitally signed & encrypted the Purchaser shall not accept such open Bids for evaluation purpose and shall be treated as non-responsive and rejected.
- 1.18.4 Bidders are advised to go through “Bidder Manual Kit”, “System Settings” & “FAQ” links available on the login page of the e-Tender portal for guidelines, procedures & system requirements. In case of any technical difficulty, Bidders may contact the help desk numbers & email ids mentioned at the e-tender portal. Every Bidder will be required to obtain a Class-III Digital Signature (DSC) for submission of Bids.
- 1.18.5 Bidders are advised to visit CPPP website <https://etenders.gov.in> regularly to keep themselves updated, for any changes/modifications in the Tender Enquiry Document.
- 1.18.6 Intending bidders are advised to visit CPPP website <https://etenders.gov.in> regularly till closing date of submission of bid, for any corrigendum.
- 1.18.7 The Bid Security/Earnest Money Deposit shall be deposited through Bank Guarantee / Demand Draft drawn in favour of “The Director, National Metallurgical Laboratory, Jamshedpur”. The original Bid Security/EMD must be delivered at address mentioned in Sr.No.2 of NIT till bid submission date and time as mentioned in “Date Sheet” failing which the bid shall be summarily rejected.
- 1.18.8 Purchaser shall receive the bids online through CPPP portal only. The e-Tender portal shall automatically stop accepting bids after the scheduled date and time specified in the Tender Document. Partially submitted bids shall be treated as invalid and shall not be processed.

1.19 Due date for Submission of E-Bids

- 1.19.1. EMD/BS must be received by the Purchaser at the address specified in NIT not later than the time and date specified in NIT.
- 1.19.2. Bidders are advised to upload and submit their E-bids timely within due date for submission of E-Bids in view of the electronic process so as to avoid last minute issues.
- 1.19.3 The Purchaser may, at its discretion, extend the due date for submission of E-bids by amending the tender documents in accordance with Clause relating to Amendment of Bidding Documents in which case all rights and obligations of the Purchaser and Bidders previously subject to the due date will thereafter be subject to the due date as extended.

1.20 Late Submission of EMD

- 1.20.1. Any bid security/EMD received by the Purchaser after the due date for submission of bids prescribed by the Purchaser is liable to be rejected.
- 1.20.2. Bidders must note that the e-tender portal shall not permit uploading of bids after the scheduled time of submission.

1.21 Withdrawal, substitution and Modification of Bids

- 1.21.1 The bidder may withdraw, correct or modify his digitally signed bid after submission prior to the deadline for submission of bids, through provisions of e-tendering portal.
- 1.21.2 The bidder is not allowed to modify or withdraw bid after deadline for submission of bids.

E. Opening and Evaluation of E-Bids

1.22 Opening of E-Bids by the Purchaser

- 1.22.1 The E-bids shall be opened online by authorised officials of the Purchaser as per schedule given in Date Sheet.
- 1.22.2 In case, the day of bid opening is declared a holiday by the government, the E-bids will be opened on the next working day at the same time. No separate intimation shall be sent to the bidders in this regard.
- 1.22.3 Since, E-bid is an online process; the E-bid opening or any other process may be delayed due to any technical/server issue. If any such issue arises, this will not be tantamount to process delay and CSIR-NML will not be responsible for the same.
- 1.22.4 On opening of bids online, accepting the bid will not mean that the firm is technically or financially qualified.
- 1.22.5 Price Bid of bidders will be opened only if Technical Bid is found compliant in all respects.

1.23 Confidentiality

- 1.23.1. Information relating to the examination, evaluation, comparison, and post qualification of bids, and recommendation of contract award, shall not be disclosed to bidders or any other persons not officially concerned with such process until Award of the Contract.
- 1.23.2. Any effort by a Bidder to influence the Purchaser in the examination, evaluation, comparison, and post qualification of the bids or contract award decisions may result in the rejection of its Bid.

1.24 Clarification of Bids

To assist in the examination, evaluation, comparison and post qualification of the bids, the Purchaser may, at its discretion, ask the Bidder for a clarification of its bid. The request for clarification and the response shall be in writing and no change in prices or substance of the bid shall be sought, offered or permitted. However, no negotiation shall be held except with the lowest bidder, at the discretion of the purchaser. Any clarification submitted by a bidder in respect to its bid which is not in response to a request by the purchaser shall not be considered. Refer to Para 1.31 (iv).

1.25 Preliminary Examination

- 1.25.1. The Purchaser shall examine the bids to confirm that all documents and technical documentation requested in **ITB Clause 1.9** have been provided, and to determine the completeness of each document submitted.
- 1.25.2. The Purchaser shall confirm that the following documents and information have been provided in the Bid. If any of these documents or information is missing, the offer shall be rejected.
 - (a) All the tenders received will first be scrutinized to see whether the tenders meet the basic requirements as incorporated in the tender enquiry document. The tenders, who do not meet the basic requirements, will be treated as non-responsive and ignored. The following are some of the important points, for which a tender may be declared as non-responsive and will be ignored, during the initial scrutiny:

i	The Bid is unsigned
ii	The Bidder is not eligible
iii	The Bid validity is shorter than the required period
iv	The Bidder has quoted for goods manufactured by a different firm without the required authority letter from the proposed manufacturer
	Bidder has not agreed to give the required performance security
vi	The goods quoted are sub-standard, not meeting the required specification, etc.

vii	Against the Requirement (Scope of supply) the bidder has not quoted for the entire requirement as specified in Chapter 4
viii	The bidder has not agreed to some essential condition(s) incorporated in the tender.
ix	The Bidder has not agreed to the delivery schedule and Payment Terms of the purchaser as mentioned in the Tender Documents.
x	The Bidder has not agreed to the submission of PBG / Performance Security.

- (b) Bid Form and Price Schedule Form, in accordance with **ITB Clause 1.10**. In case of two-bid system these forms shall be examined after opening of the Price Bids of the technically qualified bidders.

1.26 Responsiveness of Bids

- 1.26.1. Prior to the detailed evaluation, the purchaser will determine the substantial responsiveness of each bid to the bidding documents. For purposes of this clause, a substantive responsive bid is one, which conforms to all terms and condition of the bidding documents without material deviations, reservations or omissions. A material deviation, reservation or omission is one that:

(a)	affects in any substantial way the scope, quality, or performance of the Goods and Related Services specified in the Tender; OR
(b)	limits in any substantial way, inconsistent with the Bidding Documents, the Purchaser's rights or the Bidder's obligations under the Proposed Contract; OR
(c)	if rectified, would unfairly affect the competitive position of other bidders presenting substantially responsive bids.

- 1.26.2. The Purchasers' determination of a bid's responsiveness is to be based on the contents of the bid itself without recourse to extrinsic evidence.

- 1.26.3. If a bid is not substantially responsive, it will be rejected by the Purchaser and may not subsequently be made responsive by the Bidder by correction of the material deviation, reservation or omission.

1.27 Non-Conformity, Error and Omission

- 1.27.1. Provided that a Bid is substantially responsive, the Purchaser may waive any non-conformities or omissions in the Bid that do not constitute a material deviation.

- 1.27.2. Provided that a bid is substantially responsive, the Purchaser may request that the Bidder submit the necessary information or documentation, within a reasonable period of time, to rectify non-material non-conformities or omissions in the bid related to documentation requirements. Such omission shall not be related to any aspect of the price of the Bid. Failure of the Bidder to comply with the request may result in the rejection of its Bid.

- 1.27.3. Provided that the Bid is substantially responsive, the Purchaser shall correct arithmetical errors on the following basis:

(a)	if there is a discrepancy between the unit price and the line item total that is obtained by multiplying the unit price by the quantity, the unit price shall prevail and the line item total shall be corrected, unless in the opinion of the Purchaser there is an obvious misplacement of the decimal point in the unit price, in which case the line item total as quoted shall govern and the unit price shall be corrected;
(b)	if there is an error in a total corresponding to the addition or subtraction of subtotals, the subtotals shall prevail and the total shall be corrected; and
(c)	if there is a discrepancy between words and figures, the amount in words shall prevail, unless the amount expressed in words is related to an arithmetic error, in which case the amount in figures shall prevail subject to (a) and (b) above.

- 1.27.4. Provided that a bid is substantially responsive, the purchaser may request that a bidder may confirm the correctness of arithmetic errors as done by the purchaser within a target date. In case, no reply is received then the bid submitted shall be ignored and its Bid Security may be forfeited.

1.28 Examination of Terms & Conditions, Technical Evaluation

- 1.28.1. The Purchaser shall examine the Bid to confirm that all terms and conditions specified in the GCC and the SCC have been accepted by the Bidder without any material deviation or reservation.

1.28.2. The Purchaser shall evaluate the technical aspects of the Bid submitted in accordance with **ITB Clause 1.14**, to confirm that all requirements specified in Chapter 4 of the Bidding Documents have been met without any material deviation or reservation.

1.28.3. If, after the examination of the terms and conditions and the technical evaluation, the Purchaser determines that the Bid is not substantially responsive in accordance with **ITB Clause 1.26**, it shall reject the Bid.

1.29 Conversion to Single Currency

To facilitate evaluation and comparison, the Purchaser will convert all bid prices expressed in the amounts in various currencies in which the bid prices are payable to Indian Rupees at the selling exchange rate established by any bank in India as notified in the Newspapers on the date of bid opening in the case of single bid and the rates prevalent on the date of opening of the Price Bids in case of two-bid. For this purpose, exchange rate notified in www.xe.com or www.rbi.org or any other website would be used by the purchaser.

1.30 Evaluation and comparison of bids

1.30.1. The Purchaser shall evaluate each bid that has been determined, up to this stage of the evaluation, to be substantially responsive.

1.30.2. To evaluate a Bid, the Purchaser shall only use all the factors, methodologies and criteria defined below. No other criteria or methodology will be used.

1.30.3. The bids shall be evaluated on the basis of Final landing cost which shall be arrived as under:

(a) For Goods manufactured within India

i)	The price of the goods quoted Ex-works
ii)	GST which will be payable on the goods if the contract is awarded.
iii)	The charges for inland transportation, insurance and other local services required for delivering the goods at the desired destination as specified in the price schedule form.
iv)	The installation, commissioning and training charges including any incidental services, if any as given in Scope of Supply (Chapter 4)

(b) For Goods manufactured abroad

i)	The price of the goods, quoted on FCA (named Airport abroad) or FOB (named port of shipment), as specified in the price schedule form.
ii)	The charges for insurance and transportation of the goods to the port / place of destination i.e. CIP/CIF Price.
iii)	The agency commission charges payable to Indian agent in Indian rupees, if any.
iv)	The installation, commissioning and training charges including any incidental services, if any

1.30.4. The comparison between the indigenous and the foreign offers shall be made on FOR destination basis and CIF / CIP basis respectively. However, the CIF / CIP prices quoted by any foreign bidder shall be loaded further as under:-

(a) Towards customs duty and other statutory levies – as per applicable rates.

(b) Towards custom clearance, inland transportation etc.- 2% of the CIF / CIP value.

1.30.5. In case of Purchase of many items against one tender, which are not inter- dependent or, where compatibility is not a problem, normally the comparison would be made on ex-works, (in case of indigenous items) and on FOB / FCA (in the case of imports) prices quoted by the firms for identifying the lowest quoting firm for each item in the light of Para 1.31 (iv).

1.30.6. Orders for Imported Goods need not necessarily be on FOB / FCA basis rather it can be on the basis of any of the Incoterms latest edition as may be amended from time to time by the ICC or any other designated authority and favourable to CSIR -NML.

1.30.7. Wherever the price quoted on FOB / FCA and CIF / CIP basis are the same, the Contract would be made on CIF / CIP basis only.

1.30.8. The GCC and the SCC shall specify the mode of transport i.e. whether by air / ocean / road / rail.

1.31 Comparison of Bids

- (i) The Purchaser shall compare all substantially responsive bids to determine the lowest valued bid, in accordance with **ITB Clause 1.30**.
 - (ii) The total price of PART-A, PART-B, PART-C and mandatory spares added together will be considered for evaluation and for deciding the lowest quote. Price comparison will not be done separately for Part- A, Part- B & Part- C.
 - (iii) Bidder quoting lowest total price among the technically successful bidders will qualify for the award of contract, Subject to Para 1.31 (iv).
 - (iv) **Preference to Make in India**
Pursuant to Government of India, Ministry of Commerce and Industry, Department of Industrial Policy and Promotion Order No. P-45021/2/2017-B.E.-II Dated 15th June, 2017 with subject Public Procurement (Preference to Make in India), Order 2017 -
- (a) (i.) Among all qualified bids, the lowest bid will be termed as L1. If L1 is from a local supplier, the contract will be awarded to L1.
 - (ii.) If L1 is not from a local supplier, the lowest bidder among the local suppliers, will be invited to match the L1 Price subject to local supplier's quoted price falling within margin of purchase preference, and the contract shall be awarded to such local supplier subject to matching the L1 price.
 - (iii.) In case such lowest eligible local supplier fails to match the L1 price, the local supplier with the next higher bid within the margin of purchase preference shall be invited to match the L1 price and so on and contract shall be awarded accordingly. In case none of the local suppliers within the margin of purchase preference matches the L1 price, then the contract will be awarded to the L1 bidder. (Para 3c of the order dated 15th June 2017 above)
 - (b) The minimum local content shall ordinarily be 50%. (Para 5 of the order dated 15th June 2017 above)
 - (c) The margin of Purchase Preference shall be 20%. (Para 6 of the order dated 15th June 2017 above)
 - (d) In case of procurement for a value in excess of Rs. 10 Crores, the local supplier shall be required to provide a certificate from the statutory auditor or cost auditor of the company (in the case of companies) or from a practicing cost accountant and practicing chartered accountant (in respect of suppliers other than companies) giving the percentage of local content. (Para 9b of the order dated 15th June 2017 above)
 - (e) False declarations will be in breach of code of integrity under Rule 175(1)(i)(h) of the General Financial Rules 2017 for which the bidder or its successors can be debarred for upto two years as per Rule 151 (iii) of the General Financial Rules 2017 along with such further actions as may be permissible under law. (Para 9f of the order dated 15th June 2017 above)
 - (f) **No provision whatsoever in this document shall prevent the purchaser from implementing the Government of India, Ministry of Commerce and Industry, Department of Industrial Policy and Promotion Order No. P-45021/2/2017-B.E.-II Dated 15th June, 2017 with subject Public Procurement (Preference to Make in India), Order 2017.**

1.32 Contacting the Purchaser

- 1.32.1. Subject to **ITB Clause 1.24**, no Bidder shall contact the Purchaser on any matter relating to its bid, from the time of the bid opening to the time the Contract is awarded.
- 1.32.2. Any effort by a Bidder to influence the Purchaser in its decisions on bid evaluation, bid comparison or contract award may result in rejection of the Bidder's bid. In case it becomes apparent that a party is trying to influence the decision on bid evaluation then The Director, CSIR- NML through a notification may enforce restriction in visiting days and time to CSIR- NML premises for all unresponsive bidders since frequent purposeless visits of the unresponsive bidder leads to delay in file processing thereby leading to delay in research projects.

1.33 Post qualification

- 1.33.1. In the absence of pre-qualification, the Purchaser will determine to its satisfaction whether the Bidder that is selected as having submitted the lowest evaluated responsive bid is qualified to perform the contract satisfactorily, in accordance with the criteria listed in **ITB Clause 1.13**.

- 1.33.2. The determination will take into account the Eligibility & Qualification criteria listed in the bidding documents and will be based upon an examination of the documentary evidence of the Bidder's qualifications submitted by the Bidder, as well as such other information as the Purchaser deems necessary and appropriate.
- 1.33.3. An affirmative determination will be a prerequisite for award of the contract to the Bidder. A negative determination will result in rejection of the Bidder's bid.

F. Award of contract

1.34 Negotiations

Normally, there shall not be any negotiation. Negotiations, if at all, shall be an exception and only in the case of items with limited source of supply. Negotiations shall be held with the lowest evaluated responsive bidder. Counter offers tantamount to negotiations, shall be treated at par with negotiations. Negotiations will be held only in conformity of Government of India, Ministry of Commerce and Industry, Department of Industrial Policy and Promotion Order No. P-45021/2/2017-B.E.-II Dated 15th June, 2017 with subject Public Procurement (Preference to Make in India), Order 2017.

1.35 Award Criteria

Subject to **ITB Clause 1.37**, the Purchaser will award the contract to the successful Bidder whose bid has been determined to be substantially responsive and has been determined to be the lowest evaluated bid, provided further that the Bidder is determined to be qualified to perform the contract satisfactorily. The details of the award would be hosted on the CPPP website <https://etenders.gov.in>.

1.36 Purchaser's right to vary Quantities at Time of Award or later

The Purchaser reserves the right at the time of Contract award to increase or decrease the quantity of goods and services originally specified in the Chapter 4 without any change in unit price or other terms and conditions. Further, at the discretion of the purchaser, the quantities in the contract may be enhanced by 30% within the delivery period.

1.37 Purchaser's right to accept any Bid and to reject any or all Bids

The Purchaser reserves the right to accept or reject any bid, and to annul the bidding process and reject all bids at any time prior to award of Contract, without thereby incurring any liability to the affected Bidder or Bidders.

1.38 Notification of Award

- 1.38.1. Prior to the expiration of the period of bid validity, the Purchaser will notify the successful bidder in writing by registered letter or by e mail that the bid has been accepted and a separate purchase order shall follow through post.
- 1.38.2. Until a formal contract is prepared and executed, the notification of award should constitute a binding contract.
- 1.38.3. Upon the successful Bidder's furnishing of the signed Contract Form and Performance Security pursuant to **ITB Clause 1.41**, the Purchaser will promptly notify each unsuccessful Bidder and discharge its bid security.

1.39 Signing of Contract

- 1.39.1. Promptly after notification, the Purchaser shall send the successful Bidder the Purchase Order.
- 1.39.2. Within twenty-one (21) days of date of the Purchase Order, the successful Bidder shall enter into Contract Agreement as per Chapter 7.

1.40 Order Acceptance

- 1.40.1. The successful bidder should submit Order acceptance within 15 days from the date of issue of Purchase Order, failing which it shall be presumed that the vendor is not interested and his bid security is liable to be forfeited pursuant to **ITB Clause 1.15.11**.
- 1.40.2. The order acceptance must be received within 15 days. However, the Purchaser has the powers to extend the time frame for submission of order acceptance and submission of Performance Security (PS). Even after extension of time, if the order acceptance / PS are not received, the contract shall be

cancelled and limited tenders irrespective of the value shall be invited from the responding firms after forfeiting the bid security of the defaulting firm, where applicable, provided there is no change in specifications. In such cases the defaulting firm shall not be considered again for re-tendering in the particular case.

1.41 Performance Security

Within 21 days of receipt of the notification of award / Purchase Order as per the GCC Clause 2.12, the Supplier shall furnish Performance Security for the amount specified in SCC, valid for the time 60 days after the warranty period.

1.42 Assistance to Bidders:

1.42.1 Any queries relating to the Tender Enquiry Document and the terms and conditions contained therein should be addressed to the Tender Inviting Authority for a tender or the relevant contact person indicated in the NIT.

1.42.2 Any queries relating to the process of online bid submission or queries relating to CPP Portal in general may be directed to the 24x7 CPP Portal Helpdesk.

1.43 Quality Assurance & Inspection

- a. All materials, components, and equipments covered under this tender specification shall be procured, manufactured, erected, commissioned and tested at all the stages as per a comprehensive Quality Assurance Program (QAP). It is bidder's responsibility to draw such QAP. QAP will be prepared by the bidder and to be provided along with technical bid, which will be approved by CSIR- NML technical committee after modifications, if any required.
- b. Schedule of finalization of such quality plans shall be finalized before procurement/fabrication of such items.
- c. It will be the responsibility of the bidder to adhere to the approved Quality Plans.
- d. Bidder to note that all the costs involved in the various Inspections and testings as per approved QAP shall be deemed to be included in bidder's quoted price. Bidder at no point of time shall be eligible to raise any extra claim on account of any requirement necessitated as a part of approval of QAP.
- e. At various stages of manufacturing, procurement, construction, as per approved QAP inspection/ testing shall be carried out by Inspection Agency (CSIR-NML / Third Party appointed by CSIR-NML). The inspection agency shall be indicated in the QAP at the time of approval by CSIR-NML and shall be as per the approved QAP which will be handed over alongwith the Purchase Order.
- f. It will be the prerogative of CSIR- NML to mark the parts/lots or components thereof for pre-dispatch inspection. This would be mentioned in the QAP. Bidder shall notify in writing to CSIR-NML, at least two weeks (Ten working days) in advance of the date and the place at which the items will be ready for witnessing of inspection /testing (Pre-

dispatch inspection).

- g. Where ever applicable, material shall not be dispatched from the manufacturer's works before the same is accepted, subsequent to pre-dispatch final inspection including verification of records of all previous test / inspections by CSIR-NML/authorized Inspection Agency.
- h. For concrete works, successful bidder has to maintain the Test reports as per the prevailing standard practices/procedures of CPWD which are to be submitted to the technical committee during execution stage for CSIR-NML consent.

CHAPTER 2
CONDITIONS OF CONTRACT

A. GENERAL CONDITIONS OF CONTRACT

Clause No.	Contents	Page No.
2.1	Definitions	25
2.2	Contract Documents	25
2.3	Fraud and Corruption	25
2.4	Joint Venture, Consortium or Association / Amalgamation / Acquisition, Patent Indemnity	26
2.5	Scope of Supply	26
2.6	Suppliers' Responsibilities	26
2.7	Contract price	27
2.8	Copy Right	27
2.9	Application	27
2.10	Standards	27
2.11	Use of Contract Documents and Information	27
2.12	Performance Security	27
2.13	Installation, Commissioning, Demonstration, Inspection and Tests	28
2.14	Packing	28
2.15	Delivery and Documents	28-29
2.16	Insurance	30
2.17	Transportation	30
2.18	Incidental Services	31
2.19	Spare Parts	31
2.20	Warranty	31
2.21	Terms of Payment	32
2.22	Change Orders and Contract Amendments	33
2.23	Assignment	33
2.24	Subcontracts	33
2.25	Extension of time	33
2.26	Penalty Clause	33
2.27	Termination for Default	33
2.28	Force Majeure	34
2.29	Termination for insolvency	34
2.30	Termination for Convenience	34
2.31	Settlement of Disputes	35
2.32	Governing Language	35
2.33	Applicable Law	35
2.34	Notices	35
2.35	Taxes and Duties	35
2.36	Right to use Defective Goods	36
2.37	Protection against Damage	36
2.38	Site preparation and installation	36
2.39	Integrity Pact	36

Note: The General Conditions of Contract shall form the part of Purchase Order / Contract.

A. GENERAL CONDITIONS OF CONTRACT

2.1. Definitions

The following words and expressions shall have the meanings hereby assigned to them:

Sr. No.	Words / Expressions	Meaning
(a)	Contract	The Contract Agreement entered into between the Purchaser and the Supplier, together with the Contract Documents referred to therein, including all attachments, appendices, and all documents incorporated by reference therein.
(b)	Contract Documents	The documents listed in the Contract Agreement, including any amendments thereto.
(c)	Contract Price	The price payable to the Supplier as specified in the Contract Agreement, subject to such additions and adjustments thereto or deductions there from, as may be made pursuant to the Contract.
(d)	Day	Calendar day
(e)	Completion	The fulfilment of the Related Services by the Supplier in accordance with the terms and conditions set forth in the Contract.
(f)	GCC	The General Conditions of Contract.
(g)	Goods	All of the commodities, raw material, machinery and equipment, and/or other materials that the Supplier is required to supply to the Purchaser under the Contract
(h)	Services	The services incidental to the supply of the goods, such as transportation, insurance, installation, training and initial maintenance and other such obligations of the Supplier under the Contract.
(i)	SCC	The Special Conditions of Contract.
(j)	Subcontractor	Any natural person, private or government entity, or a combination of the above, to which any part of the Goods to be supplied or execution of any part of the Related Services is subcontracted by the Supplier.
(k)	Supplier	The natural Person, Private or Government entity, or a combination of the above, whose bid to perform the Contract has been accepted by the Purchaser and is named as such in the Contract Agreement.
(l)	Council	The Council of Scientific & Industrial Research (CSIR), registered under the Societies Registration Act, 1860 of the Government of India having its registered office at 2, Rafi Marg, New Delhi-110001, India.
(m)	Purchaser	Any of the constituent Laboratory/Institute of the Council situated at any designated place in India as specified in SCC
(n)	The Final destination	The place named in the SCC.

2.2 Contract Documents

2.2.1 Subject to the order of precedence set forth in the Contract Agreement, all documents forming the Contract (and all parts thereof) are intended to be correlative, complementary, and mutually explanatory. The Contract Agreement shall be read as a whole.

2.2.2 Successful bidder shall have to enter into Contract Agreement on Rs.500/- non judicial stamp paper as per Contract Form given in Chapter 7 within 21 days of placement of Purchase Order having value above Rs. 25 Lacs or equivalent amount in Foreign Currency.

2.3 Fraud and Corruption

The purchaser requires that bidders, suppliers, contractors and consultants, if any, observe the highest standard of ethics during the procurement and execution of such contracts. In pursuit of this policy,

(a) The terms set forth below are defined as follows:

I	Corrupt practice	The offering, giving, receiving, or soliciting, directly or indirectly, of anything of value to influence the action of a public official in the procurement process or in contract execution
---	------------------	---

II	Fraudulent practice	A misrepresentation or omission of facts in order to influence a procurement process or the execution of a contract
III	Collusive practice	A scheme or arrangement between two or more bidders, with or without the knowledge of the Borrower, designed to establish bid prices at artificial, non-competitive levels
IV	Coercive practice	Harming or threatening to harm, directly or indirectly, persons or their property to influence their participation in the procurement process or affect the execution of a contract

- (b) The purchaser will reject a proposal for award if it determines that the Bidder recommended for award has, directly or through an agent, engaged in corrupt, fraudulent, collusive or coercive practices in competing for the Contract in question.

2.4 **Joint Venture, Consortium or Association/Amalgamation/Acquisition, Patent Indemnity etc.**

If the Supplier is a joint venture, consortium, or association, all of the parties shall be jointly and severally liable to the Purchaser for the fulfilment of the provisions of the Contract and shall designate one party to act as a leader with authority to bind the joint venture, consortium, or association. The composition or the constitution of the joint venture, consortium, or association shall not be altered without the prior consent of the Purchaser.

2.4.1. **Amalgamation/Acquisition etc.:**

In the event the Manufacturer/Supplier proposes for amalgamation, acquisition or sale its business to any firm during the contract period, the Buyer/Successor of the Principal Company are liable for execution of the contract and also fulfilment of contractual obligations i.e. supply, installation, commissioning, warranty, maintenance/replacement of spares accessories etc. You may confirm this condition while submitting the bid.

2.4.2 **Indemnity Bond**

In order to safeguard the interest of CSIR-NML, the supplier should submit Indemnity Bond as given in Chapter-8 (Annexure-J) on Rs.500/- non judicial stamp paper within 21 days of placing of the order for Purchase Order having value above Rs. 25 lakh or equivalent amount in Foreign Currency.

2.4.3 **Patent Indemnity**

- a) The Supplier shall, subject to the Purchaser's compliance with GCC Sub-Clause 2.4.3(a), indemnify and hold harmless the Purchaser and its employees and officers from and against any and all suits, actions or administrative proceedings, claims, demands, losses, damages, costs, and expenses of any nature, including attorney's fees and expenses, which the Purchaser may suffer as a result of any infringement or alleged infringement of any patent, utility model, registered design, trademark, copyright, or other intellectual property right registered or otherwise existing at the date of the Contract by reason of:

(I)	the installation of the Goods by the Supplier or the use of the Goods in India
AND	
(II)	the sale in any country of the products produced by the Goods

- b) If any proceedings are brought or any claim is made against the Purchaser, the Purchaser shall promptly give the Supplier a notice thereof and the Supplier may at its own expense and in the Purchaser's name conduct such proceedings or claim and any negotiations for the settlement of any such proceedings or claims.

2.5 **Scope of Supply**

Scope of Supply (i.e. the Goods to be supplied and Related Services to be performed) shall be as specified in the Chapter-4.

2.6 **Suppliers' Responsibilities**

The Supplier shall supply all the Goods and perform all Related Services included in the Scope of Supply-Clause 2.5 of the GCC and the Delivery &Completion Schedule, as per GCC Clause 2.15 relating to delivery and document.

2.7 Contract price

Prices charged by the Supplier for the Goods supplied and the Related Services performed under the Contract shall not vary from the prices quoted by the Supplier in its bid.

2.8 Copy Right

The copyright in all drawings, documents, and other materials containing data and information furnished to the Purchaser by the Supplier herein shall remain vested in the Supplier, or, if they are furnished to the Purchaser directly or through the Supplier by any third party, including suppliers of materials, the copyright in such materials shall remain vested in such third party

2.9 Application

These General Conditions shall apply to the extent that they are not superseded by provisions in other parts of the Contract.

2.10 Standards

The Goods supplied and services rendered under this Contract shall conform to the standards mentioned in the Technical Specifications and Schedule of Requirements, and, when no applicable standard is mentioned, to the authoritative standard appropriate to the Goods' country of origin and such standards shall be the latest issued by the concerned institution.

2.11 Use of Contract Documents and Information

2.11.1 The Supplier shall not, without the Purchaser's prior written consent, disclose the Contract, or any provision thereof, or any specification, plan, drawing, pattern, sample or information furnished by or on behalf of the Purchaser in connection therewith, to any person other than a person employed by the Supplier in performance of the Contract. Disclosure to any such employed person shall be made in confidence and shall extend only so far, as may be necessary for purposes of such performance.

2.11.2 The Supplier shall not, without the Purchaser's prior written consent, make use of any document or information enumerated above except for purposes of performing the Contract.

2.11.3 Any document, other than the Contract itself, enumerated above shall remain the property of the Purchaser and shall be returned (in all copies) to the Purchaser on completion of the Supplier's performance under the Contract if so required by the Purchaser.

2.12 Performance Security (PS)

2.12.1 Within 21 days of receipt of the notification of award of contract / Purchase Order, the Supplier shall furnish performance security in the amount specified in SCC, valid till 60 days after the warranty period. Alternatively, the PS may also be submitted at the time of release of Final payment in cases where part payment is made against delivery & part on installation. The PS, where applicable, shall be submitted in advance for orders where full payment is to be made on Letter of Credit (LC) or on delivery. In this case, submission of PS at the time of negotiation of documents through Bank would be stipulated as a condition in the LC and the BS should be kept valid till such time the PS is submitted.

2.12.2 The proceeds of the performance security shall be payable to the Purchaser as compensation for any loss resulting from the Supplier's failure to complete its obligations under the Contract.

2.12.3 The Performance Security shall be denominated in Indian Rupees for the offers received for supplies within India and denominated in the currency of the contract in the case of offers received for supply from foreign countries.

2.12.4 In the case of imports, the PS may be submitted either by the principal or by the Indian agent and, in the case of purchases from indigenous sources, the PS may be submitted by either the manufacturer or their authorized dealer / bidder.

2.12.5 The Performance security shall be in one of the following forms:

(a)	A Bank guarantee or stand-by Letter of Credit issued by a Nationalized / Scheduled bank located in India or a bank located abroad in the form provided in the bidding documents.
OR	
(b)	A Banker's cheque or Account Payee demand draft in favour of the purchaser.

2.12.6 The performance security will be discharged by the Purchaser and returned to the Supplier not later than 60 days following the date of completion of the Supplier's performance obligations, including any warranty obligations, unless specified otherwise in SCC, without levy of any interest.

2.12.7 In the event of any contract amendment, the supplier shall, within 21 days of receipt of such amendment, furnish the amendment to the performance security, rendering the same valid for the duration of the contract, as amended for further period of 60 days thereafter.

2.12.8 The order confirmation should be received within 15 days from the date of notification of award. However, the Purchaser has the powers to extend the time frame for submission of order confirmation and submission of Performance Security (PS). Even after extension of time, if the order acceptance and PS are not received, the contract shall be cancelled and limited tenders irrespective of the value would be invited from the responding firms after forfeiting the bid security of the defaulting firm, where applicable provided there is no change in specifications. In such cases the defaulting firm would not be considered again for re-tendering in the particular case.

2.12.9 Whenever, the bidder chooses to submit the Performance Security in the form of Bank Guarantee, and then he should advise the banker issuing the Bank Guarantee to immediately send by Registered Post (A.D.) an unstamped duplicate copy of the Guarantee directly to the Purchaser with a covering letter to compare with the original BG for the correctness, genuineness, etc.

2.13 Installation, Commissioning, Demonstration, Inspections and Tests

Bidder shall be responsible for Installation, Commissioning, Demonstration, Inspections and Tests wherever applicable and for after sales service during the warranty and thereafter as specified in Chapter 4.

2.14 Packing

2.14.1. The Supplier shall provide such packing of the Goods as is required to prevent their damage or deterioration during transit to their Final destination as indicated in the Contract. The packing shall be sufficient to withstand, without limitation, rough handling during transit and exposure to extreme temperatures, salt and precipitation during transit and open storage. Packing case size and weights shall take into consideration, where appropriate, the remoteness of the Goods' Final destination and the absence of heavy handling facilities at all points in transit.

2.14.2. The packing, marking and documentation within and outside the packages shall comply strictly with such special requirements as shall be provided for in the Contract including additional requirements, if any, specified in SCC and in any subsequent instructions ordered by the Purchaser.

2.15 Delivery and Documents

2.15.1. Delivery of the Goods and completion and related services shall be made by the Supplier in accordance with the terms specified by the Purchaser in the contract. The details of shipping and/or other documents to be furnished by the supplier are as given below or /and as specified in SCC.

Details of Shipping and other Documents to be furnished by the Supplier are :

A) For goods manufactured or supplied from within India

Within 24 hours of dispatch, the supplier shall notify the purchaser the complete details of dispatch and also supply following documents by registered post / speed post and copies thereof by email.

- (a) Three copies of Supplier's Invoice indicating, inter-alia description and specification of the goods, quantity, unit price, total value

- (b) Packing list
- (c) Certificate of country of origin
- (d) Insurance certificate, if required under the contract
- (e) Railway receipt/Consignment note
- (f) Manufacturer's warrantee certificate and in-house inspection certificate, if any
- (g) Inspection certificate issued by purchaser's inspector, if any
- (h) Any other document(s) as and when required in terms of the contract

NOTE:

- 1 The nomenclature used for the item description in the invoice(s), packing list(s) and the delivery note(s) etc. should be identical to that used in the contract. The dispatch particulars including the name of the transporter should also be mentioned in the Invoice(s).
- 2 The above documents should be received by the Purchaser before arrival of the Goods and, if not received, the Supplier will be responsible for any consequent expenses.

B) For goods manufactured or supplied from abroad

Within 24 hours of dispatch, the supplier shall notify the purchaser the complete details of dispatch and also supply following documents by Registered Post / courier and copies thereof by email.

- (a) Three copies of supplier's Invoice giving full details of the goods including quantity, value, etc.
- (b) Packing list
- (c) Certificate of country of origin
- (d) Manufacturer's warrantee and Inspection certificate, if any
- (e) Inspection certificate issued by the Purchaser's Inspector, if any
- (f) Insurance Certificate, if required under the contract
- (g) Name of the Vessel / Carrier
- (h) Bill of Lading / Airway Bill
- (i) Port of Loading
- (j) Date of Shipment
- (k) Port of Discharge & expected date of arrival of goods
- (l) Any other document(s) as and when required in terms of the contract

NOTE:

- 1 The nomenclature used for the item description in the invoice(s), packing list(s) and the delivery note(s) etc. should be identical to that used in the contract. The dispatch particulars including the name of the transporter should also be mentioned in the Invoice(s).
- 2 The above documents should be received by the Purchaser before arrival of the Goods and, if not received, the Supplier will be responsible for any consequent expenses.

The clearing of the consignment at Kolkata Airport shall be done by our authorized Custom House Agents (CHA). The corresponding shipping documents may be forwarded to them accordingly. It is advised to give us and our CHA, a pre-alert before the consignment is dispatched. If there is delay in clearing of the consignment for not giving timely pre-alert then demurrage (Ware house charges), if applicable has to be refunded to us.

- 2.15.2. The terms FOB, FCA, CIF, CIP etc. shall be governed by the rules prescribed in the current edition of the Incoterms published by the International Chambers of Commerce (ICC), Paris.
- 2.15.3. The mode of transportation shall be as specified in SCC.
- 2.15.4. The Bidders may please note that the delivery of the system should be strictly within delivery schedule mentioned in the Chapter-4 / Purchase Order.
- 2.15.5. Goods should not be dispatched until the vendor receives a firm Purchase Order

2.16 Insurance

- 2.16.1. Indigenous goods, the Goods supplied under the Contract shall be fully insured in Indian Rupees against any loss or damage incidental to manufacture or acquisition, transportation, storage and delivery in the manner specified in SCC.
- 2.16.2. Where delivery of the goods is required by the purchaser on CIF / CIP basis for imported goods or FOR destination for Indigenous goods, the supplier shall arrange and pay for Marine / Transit Insurance, naming the purchaser as beneficiary and initiate & pursue claims till settlement, in the event of any loss or damage.
- 2.16.3. Where delivery is on FOB or FCA basis for imported goods or FOR dispatch station for indigenous goods, then insurance would be the responsibility of the purchaser.
- 2.16.4. The equipments to be supplied will be insured by the supplier against all risks of loss or damage from the date of shipment till such time it is delivered at CSIR-NML site in case of Rupee transaction
- 2.16.5. With a view to ensure that claims on insurance companies, if any, are lodged in time, the Bidders and / or the Indian agent shall be responsible for follow up with their principals for ascertaining the dispatch details and informing the same to the Purchaser and he shall also liaise with the Purchaser to ascertain the arrival of the consignment after clearance so that immediately thereafter in his presence the consignment could be opened and the insurance claim be lodged, if required, without any loss of time. Any delay on the part of the Bidder / Indian Agent would be viewed seriously and he shall be directly responsible for any loss sustained by the Purchaser on the event of the delay.

2.17 Transportation

- 2.17.1. Where the Supplier is required under the Contract to deliver the Goods on FOB basis, transport of the Goods, up to and including the point of putting the Goods on board the vessel at the specified port of loading, shall be arranged and paid for by the Supplier, and the cost thereof shall be included in the Contract price. Where the Supplier is required under the Contract to deliver the Goods on FCA basis, transport of the Goods and delivery into the custody of the carrier at the place named by the Purchaser or other agreed point shall be arranged and paid for by the Supplier, and the cost thereof shall be included in the Contract price.
- 2.17.2. Where the Supplier is required under the Contract to deliver the Goods CIF or CIP, transport of the Goods to the port of destination or such other named place of destination in the Purchaser's country, as shall be specified in the Contract, shall be arranged and paid for by the Supplier, and the cost thereof shall be included in the Contract Price.
- 2.17.3. In the case of supplies from within India, where the Supplier is required under the Contract to transport the Goods to a specified destination in India, defined as the Final Destination, transport to such destination, including insurance and storage, as specified in the Contract, shall be arranged by the Supplier, and the related costs shall be included in the Contract Price.

2.17.4. The clearing of the consignment at Kolkata Airport shall be done by our authorized Custom House Agents (CHA) for CIP / CIF consignments. The details of CHA will be given in the Purchase Order. The corresponding shipping documents may be forwarded to them accordingly. It is advised to give us and our CHA, a pre-alert before the consignment is dispatched. If there is delay in clearing of the consignment for not giving timely pre-alert then demurrage (Ware house charges), if applicable has to be refunded to us by the Supplier / Indian Agent or the same will be deducted from any payment due to Supplier / Indian Agent against this order or any other Purchase order.

2.18 Incidental Services

The supplier may be required to provide any or all of the services, including training, if any, as specified in **Chapter 4**.

2.19 Spare Parts

The Supplier shall be required to provide any or all of the following materials, notifications, and information pertaining to spare parts manufactured or distributed by the Supplier:

(a)	Such spare parts as the Purchaser may elect to purchase from the Supplier, providing that this election shall not relieve the Supplier of any warranty obligations under the Contract; and
(b)	In the event of termination of production of the spare parts:
	(i) Advance notification to the Purchaser of the pending termination, in sufficient time to permit the Purchaser to procure needed requirements; and
	(ii) Following such termination, furnishing at no cost to the Purchaser, the blueprints, drawings and specifications of the spare parts, if requested.

2.20 Warranty

- a) The Supplier warrants that all the Goods are new, unused, and of the most recent or current models, and that they incorporate all recent improvements in design and materials, unless provided otherwise in the Contract.
- b) The Supplier further warrants that the Goods shall be free from defects arising from any act or omission of the Supplier or arising from design, materials, and workmanship, under normal use in the conditions prevailing in India.
- c) **The warranty for items PART-A, PART-B and PART-C of the tender documents shall be as follows:**
 - I.) **The warranty for PART-A, PART-B and PART-C needs to be provided separately.**
 - II.) **One year comprehensive warranty for PART-A, PART-B and PART-C will be reckoned from the date of successful integration, installation and commissioning of Lot-1, Lot-2 and Lot-3 of Part - A. It will be responsibility of the successful bidder to provide comprehensive warranty even if OEM's warranty for Part-A and/or Part- B and/or Part- C or any Lot of any Part is over.**
 - III.) **(c) Party should also quote for extended warranty for PART-A, PART-B AND PART-C for a period of THREE years separately (quoting each year separately) beyond the completion of comprehensive warranty. However, extended warranty will be considered only as optional and will not be included in the evaluation of price bids. Extended warranty should be quoted separately. The supplier will transfer OEM's warranty for all components if the warranty of OEM is more than what is offered by the supplier.**
- d) The warranty on the associated software should cover providing of upgraded version/s, if any, released during the warranty period free of cost.
- e) The bidder shall assure the supply of spare parts after warranty is over for maintenance of the equipment supplied if and when required for a period of 10 years from the date of supply of equipment on payment on approved price list basis.
- f) The equipment must be supported by a Service Centre manned by the principal vendor's technical support engineers. The support through this Centre must be available 24 hours in a day, seven days a week and 365 days a year. Also it should be possible to contact the Principal's vendor support Centre on a toll free number/web/mail.

- g) An undertaking from the manufacturer is required in this regard stating that they would facilitate the Bidder, Service provider on regular basis with technology / product updates & extend support for the warranty as well.
- h) Supplier will have to arrange for all the testing equipment & tools required for installation, testing & maintenance etc.
- i) The Principal Supplier must have a local logistics support by maintaining a local spares depot in the country of deployment of the equipment. This is to ensure immediate delivery of spares parts from Principal Supplier of equipment to its channel partner/system integrator.
- j) Details of onsite warranty, Name of Agency that shall maintain during warranty and undertake Annual Maintenance Contract/Comprehensive Service Maintenance Contract beyond warranty shall be given in the offer. In case of foreign quote, the name of Indian Agent who shall maintain during warranty and AMC beyond warranty shall be given in the Technical Offer.
- k) The Purchaser shall give notice to the Supplier stating the nature of any such defects together with all available evidence thereof, promptly following the discovery thereof. The Purchaser shall afford all reasonable opportunity for the Supplier to inspect such defects.
- l) Upon receipt of such notice, the Supplier shall, within a reasonable period of time, expeditiously repair or replace the defective Goods or parts thereof, at no cost to the Purchaser.
- m) If having been notified, the Supplier fails to remedy the defect within a reasonable period of time; the Purchaser may proceed to take within a reasonable period such remedial action as may be necessary, at the Supplier's risk and expense and without prejudice to any other rights which the Purchaser may have against the Supplier under the Contract.
- n) In case the Equipment / System remains non-operational or performs below the desired level for more than 1 week after intimation of the fault in the Equipment / System then Warranty period shall be extended for further period for which Equipment / System remained non-operational or performed below the desired level, without prejudice to any other terms and conditions of the Contract.
- o) The defects, if any, during the warranty period are to be rectified free of charge by arranging free replacement wherever necessary.
- p) In case of any replacement during the warranty period the same shall be made free of cost i.e. DDP for import replacement and/or free delivery to CSIR-NML for indigenous replacement. All the duties / taxes relating to these replacements have to be borne by the supplier. Dispatch details of such warranty replacements have to be informed in advance to enable us to provide documents for custom clearance.
- q) Any replacements during warranty period should be free of cost. If the defective item has to be sent back to the Principal Supplier, for such replacements / returns to the Principal Supplier / Indian Agent has to bear documentation charges. If the cost of replacement is upto Rs. 5 Lakh then the documentation charges will be Rs. 5,000 and above Rs. 5 Lakh it is Rs. 10,000. Such charges have to be paid in favour of The Director, CSIR-NML, Jamshedpur. These charges are only for documentation. Any charges regarding packing, forwarding, freight, insurance, etc. should be borne by the Principal supplier / Indian Agent for returning of defective items. In other words, any warranty replacement has to be done immediately/within a week (7 days) without expecting CSIR-NML to export the defective items to Principal supplier for repair/replacements. All charges involved for re-export of defective items have to be borne by Principal supplier / Indian Agent.

2.21 Terms of Payment

- 2.21.1. The method and conditions of payment to be made to the Supplier under this Contract shall be as specified in the SCC.
- 2.21.2. The Supplier's request(s) for payment shall be made to the Purchaser in writing, accompanied by an invoice describing, as appropriate, the Goods delivered and the Services performed, and by documents, submitted pursuant to Delivery and document Clause of the GCC and upon fulfilment of other obligations stipulated in the contract.

2.21.3. Payments shall be made promptly by the Purchaser but in no case later than thirty (30) days after submission of the Invoice or claim by the Supplier.

2.21.4. Payment shall be made in currency as indicated in the contract.

2.22 Change Orders and Contract Amendments

2.22.1. The Purchaser may at any time, by written order given to the Supplier pursuant to Clause on Notices of the GCC make changes within the general scope of the Contract in any one or more of the following:

a)	Drawings, designs, or specifications, where Goods to be furnished under the Contract are to be specifically manufactured for the Purchaser;
b)	The method of shipping or packing;
c)	The place of delivery; and/or
d)	The Services to be provided by the Supplier.
e)	The delivery schedule.

2.22.2. If any such change causes an increase or decrease in the cost of, or the time required for, the Supplier's performance of any provisions under the Contract, an equitable adjustment shall be made in the Contract Price or delivery schedule, or both, and the Contract shall accordingly be amended. Any claims by the Supplier for adjustment under this clause must be ascertained within fifteen (15) days from the date of the Supplier's receipt of the Purchaser's change order.

2.22.3. No variation or modification in the terms of the contract shall be made except by written amendment signed by the parties.

2.23 Assignment

The Supplier shall not assign, in whole or in part, its obligations to perform under the Contract, except with the Purchaser's prior written consent.

2.24 Subcontracts

The Supplier shall notify the Purchaser in writing of all subcontracts awarded under this Contract if not already specified in the bid. Such notification, in the original bid or later, shall not relieve the Supplier from any liability or duties or obligation under the Contract.

2.25 Extension of time

2.25.1. Delivery of the Goods and performance of the Services shall be made by the Supplier in accordance with the Delivery schedule specified by the Purchaser.

2.25.2. If at any time during performance of the Contract, the Supplier or its sub-contractor(s) should encounter conditions impeding timely delivery of the Goods and performance of Services, the Supplier shall promptly notify the Purchaser in writing of the fact of the delay, its likely duration and its cause(s). As soon as practicable after receipt of the Supplier's notice, the Purchaser shall evaluate the situation and may, at its discretion, extend the Supplier's time for performance with or without Penalty, in which case the extension shall be ratified by the parties by amendment to the Contract.

2.25.3. Except as provided under the Force Majeure clause of the GCC, a delay by the Supplier in the performance of its delivery obligations shall render the Supplier liable to the imposition of Penalty pursuant to Penalty Clause of the GCC unless an extension of time is agreed upon pursuant to above clause without the application of Penalty clause.

2.26 Penalty clause

Subject to GCC Clause on Force Majeure, if the Supplier fails to deliver any or all of the Goods or to perform the Services within the period(s) specified in the Contract, the Purchaser shall, without prejudice to its other remedies under the Contract, deduct from the Contract Price, as Penalty, a sum equivalent to the percentage specified in SCC of the delivered price of the delayed Goods or unperformed Services or contract value for each week or part thereof delay until actual delivery or performance, up to a maximum deduction of the Percentage specified in SCC. Once the maximum is reached, the Purchaser may consider termination of the Contract pursuant to GCC Clause on Termination for Default. The SCC shall also indicate the basis for ascertaining the value on which the Penalty shall be applicable.

2.27 Termination for Default

2.27.1. The Purchaser may, without prejudice to any other remedy for breach of contract, by written notice of default sent to the Supplier, terminate the Contract in whole or part:

(a)	If the Supplier fails to deliver any or all of the Goods within the period(s) specified in the contract, or within any extension thereof granted by the Purchaser pursuant to GCC Clause on Extension of Time;
(b)	If the Supplier fails to perform any other obligation(s) under the Contract
(c)	If the Supplier, in the judgment of the Purchaser has engaged in corrupt or fraudulent or collusive or coercive practices as defined in GCC Clause on Fraud or Corruption in competing for or in executing the Contract.

2.27.2. In the event the purchaser terminates the contract in whole or in part, he may take recourse to any one or more of the following action:

(a)	The Performance Security/EMD will be forfeited;
(b)	The Purchaser may procure, upon such terms and in such manner as it deems appropriate, Goods similar to those undelivered, and the supplier shall be liable for all available actions against it in terms of the contract.
(c)	However, the supplier shall continue to perform the contract to the extent not terminated.

2.28 Force Majeure

2.28.1. Notwithstanding the provisions of GCC Clauses relating to Extension of Time, Penalty and Termination for Default the Supplier shall not be liable for forfeiture of its Performance Security, Liquidated Damages or Termination for Default, if and to the extent that, its delay in performance or other failure to perform its obligations under the Contract is the result of an event of Force Majeure.

2.28.2. For purposes of this Clause, “Force Majeure” means an event or situation beyond the control of the Supplier that is not foreseeable, is unavoidable, and its origin is not due to negligence or lack of care on the part of the Supplier. Such events may include, but not be limited to, acts of the Purchaser in its sovereign capacity, wars or revolutions, fires, floods, epidemics, quarantine restrictions, and freight embargoes.

2.28.3. If a Force Majeure situation arises, the Supplier shall promptly notify the Purchaser in writing of such conditions and the cause thereof within 21 days of its occurrence. Unless otherwise directed by the Purchaser in writing, the Supplier shall continue to perform its obligations under the Contract as far as is reasonably practical, and shall seek all reasonable alternative means for performance not prevented by the Force Majeure event.

2.28.4. If the performance in whole or in part or any obligations under the contract is prevented or delayed by any reason of Force Majeure for a period exceeding 60 days, either party may at its option terminate the contract without any financial repercussions on either side.

2.29 Termination for Insolvency

The Purchaser may at any time terminate the Contract by giving written notice to the Supplier, if the Supplier becomes bankrupt or otherwise insolvent. In this event, termination will be without compensation to the Supplier, provided that such termination will not prejudice or affect any right of action or remedy, which has accrued or will accrue thereafter to the Purchaser.

2.30 Termination for Convenience

2.30.1. The Purchaser, by written notice sent to the Supplier, may terminate the Contract, in whole or in part, at any time. The notice of termination shall specify that termination is for the Purchaser's convenience, the extent to which performance of the Supplier under the Contract is terminated, and the date upon which such termination becomes effective.

2.30.2. The Goods that are complete and ready for shipment within 30 days after the Supplier's receipt of notice of termination shall be accepted by the Purchaser at the Contract terms and prices. For the remaining Goods, the Purchaser may elect:

(a)	To have any portion completed and delivered at the Contract terms and prices ; and / or
(b)	To cancel the remainder and pay to the Supplier an agreed amount for partially completed Goods / Services and for materials and parts previously procured by the Supplier.

2.31 Settlement of Disputes

2.31.1. The Purchaser and the supplier shall make every effort to resolve amicably by direct informal negotiation any disagreement or dispute arising between them under or in connection with the Contract.

2.31.2. If, after twenty-one (21) days, the parties have failed to resolve their dispute or difference by such mutual consultation, then either the Purchaser or the Supplier may give notice to the other party of its intention to commence arbitration, as hereinafter provided, as to the matter in dispute, and no arbitration in respect of this matter may be commenced unless such notice is given. Any dispute or difference in respect of which a notice of intention to commence arbitration has been given in accordance with this Clause shall be Finally settled by arbitration. Arbitration may be commenced prior to or after delivery of the Goods under the Contract.

2.31.3. The dispute settlement mechanism / arbitration proceedings shall be concluded as under:

(a)	In case of Dispute or difference arising between the Purchaser and a domestic supplier relating to any matter arising out of or connected with this agreement, such disputes or difference shall be settled in accordance with the Indian Arbitration & Conciliation Act, 1996, the rules there under and any statutory modifications or re-enactments thereof shall apply to the arbitration proceedings. The dispute shall be referred to the Director General, Council of Scientific & Industrial Research and if he is unable or unwilling to act, to the sole arbitration of some other person appointed by him willing to act as such Arbitrator. The award of the arbitrator so appointed shall be Final, conclusive and binding on all parties to the Contract.
(b)	In the case of a dispute between the purchaser and a Foreign Supplier, the dispute shall be settled by arbitration In accordance with provision of sub-clause (a) above. But if this is not acceptable to the supplier then the dispute shall be settled in accordance with provisions of UNCITRAL (United Nations Commission on International Trade Law) Arbitration Rules.

2.31.4. The venue of the arbitration shall be the place from where the Purchase Order or Contract is issued.

2.31.5. Notwithstanding any reference to arbitration herein,

(a)	the parties shall continue to perform their respective obligations under the Contract unless they otherwise agree; and
(b)	the Purchaser shall pay the Supplier any monies due the Supplier.

2.32 Governing Language

The Contract shall be written in English language which shall govern its interpretation. All correspondence and other documents pertaining to the Contract, which are exchanged by the parties, shall be written in the English language only.

2.33 Applicable Law / Jurisdiction

The Contract shall be interpreted in accordance with the laws of the Union of India and all disputes shall be subject to place of jurisdiction as specified in SCC.

2.34 Notices

2.34.1. Any notice given by one party to the other pursuant to this contract / order shall be sent to the other party in writing or by e-mail or / and confirmed in writing to the other party's address specified in the SCC.

2.34.2. A notice shall be effective when delivered or on the notice's effective date, whichever is later.

2.35 Taxes and Duties

2.35.1. For goods manufactured outside India, the Supplier shall be entirely responsible for all taxes, stamp duties, license fees, and other such levies imposed outside India.

- 2.35.2. For goods Manufactured within India, the Supplier shall be entirely responsible for all taxes, duties, license fees, etc., incurred till its final manufacture / production.
- 2.35.3. If any tax exemptions, reductions, allowances or privileges may be available to the Supplier in India, the Purchaser shall make its best efforts to enable the Supplier to benefit from any such tax savings to the maximum allowable extent.
- 2.35.4. All payments due under the contract shall be paid after deduction of statutory levies (at source) (like ESIC, IT, etc.) wherever applicable.

2.36 Right to use Defective Goods

If after delivery, installation and within commissioning & acceptance and within warranty period, the operation or use of the goods proves to be unsatisfactory, the Purchaser shall have the right to continue to operate or use such goods until rectifications of defects, errors or omissions by repair or by partial or complete replacement is made without interfering with the Purchaser's operation.

2.37 Protection against Damage

The system shall not be prone to damage during power failures and trip outs. The normal voltage and frequency conditions available at site as under:

- (a) Voltage 230 volts – Single phase or 415 Volt for 3 phase ($\pm 10\%$)
- (b) Frequency 50 Hz.

2.38 Site preparation and installation

The Purchaser is solely responsible for the construction of the equipment sites unless otherwise specified in Chapter 4 in compliance with the technical and environmental specifications defined by the Supplier. The Purchaser will designate the installation sites before the scheduled installation date to allow the Supplier to perform a site inspection to verify the appropriateness of the sites before the installation of the Equipment, if required. The supplier shall inform the purchaser about the site preparation, if any, needed for installation, of the goods at the purchaser's site immediately after notification of award / contract.

2.39 Integrity Pact

- 2.39.1. As per directive of the CVC all organizations including CSIR laboratories / institutes have to adopt an Integrity pact (IP) to ensure transparency, equity and competitiveness in major Public procurement having procurement value above Rs.3 Crore. The integrity pact envisages an agreement between the prospective bidders / vendors with the buyer committing the persons / officials of both the parties with the aim not to exercise any corrupt influence on any aspect of the contract. Only those bidders / vendors, who are willing to enter in to such an integrity pact with the Purchaser, would be competent to participate in the bidding.
- 2.39.2. IP also envisages Panel of Independent External Monitors (IEMs) which shall be provided / recommended by CSIR / its labs and institutes with the approval of by CVC.
- 2.39.3. The integrity Pact would be effective from the date of invitation of bids till complete execution of the contract.
- 2.39.4. **The SCC shall specify whether there is a need to enter into a separate integrity pact or not.** If the Integrity Pact is required for the Tender then the format of Integrity Pact is as given in **Chapter – 8.**

CHAPTER 2

B. SPECIAL CONDITIONS OF CONTRACT (SCC)

The following Special Conditions of Contract (SCC) shall supplement and / or amend the General Conditions of Contract (GCC). Whenever there is a conflict, the provisions herein shall prevail over those in the GCC.

GCC Clause	Special Condition of Contract (SCC)
GCC 2.1.1(l)	The Purchaser is: The Director CSIR- National Metallurgical Laboratory Burmamines, Jamshedpur – 831007 Jharkhand-India
GCC 2.1.1(m)	The Final Destination is: CSIR- National Metallurgical Laboratory Burmamines, Jamshedpur – 831007 Jharkhand-India
GCC 2.15.3	Delivery – Mode of Shipment: (a) In case of supplies from within India, the mode of transportation shall be by Road . (b) In case of supplies from abroad, the mode of transportation shall be by AIR
GCC 2.13.1	Performance Security/Performance Bank Guarantee The amount of the Performance Bank Guarantee shall be 10% of the contract value (including taxes) , to be submitted within 21 days from the date of PO valid up to 60 days after the date of completion of performance obligations including warranty obligations.
GCC 2.16.1	Insurance The Insurance shall be for an amount equal to 110% of the CIF or CIP value of the contract from within “warehouse to warehouse (Final destination)” on “all risk basis” including strikes, riots and civil commotion, in addition to storage policy for 60 days is advised so as to ensure the inspection by the Indian Agent at the time of opening the packages.
GCC 2.20.3	Warranty: The warranty for items PART-A, PART-B and PART-C of the tender documents shall be as follows: (a) The warranty for PART-A, PART-B and PART-C needs to be provided separately. (b) One year comprehensive warranty for PART-A, PART-B and PART-C will be reckoned from the date of successful integration, installation and commissioning of Lot-1, Lot-2 and Lot-3 of Part - A. It will be responsibility of the successful bidder to provide comprehensive warranty even if OEM’s warranty for Part-A and/or Part- B and/or Part- C or any Lot of any Part is over. (c) Party should also quote for extended warranty for PART-A, PART-B AND PART-C for a period of TWO years separately (quoting each year separately) beyond the completion of comprehensive warranty. However, extended warranty will be considered only as optional and will not be included in the evaluation of price bids. Extended warranty should be quoted separately. The supplier will transfer OEM’s warranty for all components if the warranty of OEM is more than what is offered by the supplier.
GCC 2.21.1	Payment Details: The method and conditions of payment to be made to the Supplier under this Contract shall be as follows: Kindly refer the table 2.21.1 Below NOTE: ➤ All payments due under the Contract shall be paid after deduction of statutory levies at source (like ESIC, Income Tax, etc.), wherever applicable.
GCC 2.27.1	Liquidated Damages / Penalty Clause (a) As time is the essence of the contract, Delivery period mentioned in the Purchase Order should be strictly adhered to. Otherwise the bidder will forfeit EMD/SD and also LD clause will be applicable /enforced (b) If the supplier fails to Supply, Install and Commission the system as per specifications mentioned in the order within the due date, the Supplier is liable to pay liquidated damages of 0.5% of order value per every week of delay subject to a maximum of 5% beyond the due date. Such money will be deducted from any amount due or which may become due to the supplier

	(c) CSIR-NML reserves the right to cancel the order in case the delay is more than 10 weeks. Penalties, if any, will be deducted from the Security Deposit
	(d) The maximum amount of Penalty shall be 5%.
	(e) The liquidated damages shall be levied on the delivered price of the delayed Goods or unperformed Services or contract value.
GCC 2.34.1	Applicable Law / Jurisdiction The place of jurisdiction is Jamshedpur, India.
GCC 2.35.1	Notices For notices, the Purchaser's address is The Director CSIR- National Metallurgical Laboratory Burmamines, Jamshedpur – 831007 Jharkhand-India Tel #: 00 91 657 2345129/32 Email: spo@nmlindia.org
GCC 2.41	Integrity Pact should be signed.(as per Annexure M)
SPECIAL TECHNICAL TERMS AND CONDITIONS	<p>(a) Submission and vetting of design and drawing.</p> <p>(i) Successful bidder has to submit the GA, subassembly and critical detailed drawings of equipment, crane, PEB and electrical supported with related calculations and computer aided models.</p> <p>(ii) All the drawings indicated at (a) and Technical data sheet of major purchase items shall be vetted by NML prior to manufacture / fabrication and procurement respectively. Three copies of each of these documents are to be provided. All the drawings as submitted by the Vendor needs to be approved by the technical committee of CSIR-NML.</p> <p>(iii) As-built drawings of approved drawings are to be provided in soft and hardcopies (3 copies each).</p> <p>(b) Bidder (bidder qualifying as per technical and financial compliance) has to sign Non- Disclosure Agreement (NDA) on allotment of work order.</p> <p>(c) Intellectual property rights related to all the design (including relevant calculations and modelling) and development of the process and associated equipment for the pilot plant shall be retained with CSIR-NML.</p> <p>(d) Successful bidder has to supply mandatory spares as per the schedule decided during commissioning trials. Delivery schedule of two years running spares, if included in the Purchase Order will also be decided during commissioning trials.</p> <p>(e) Bidder (successful bidder) to supply the first fills consumable and process raw materials for commissioning.</p> <p>(f) Successful bidder shall provide Indian as well as foreign source of raw materials (ultralow carbon steel, Ferro boron / boron, ferrosilicon/silicon etc.) and critical spares.</p> <p>(g) Successful bidder shall submit soft and hard (3 nos.) copies of operation and maintenance manuals of different units.</p> <p>(h) Development of SOP: CSIR-NML personnel will develop SOP for production of amorphous electrical steel ribbon / sheet of 100 mm wide and 20 to 25-micron thickness at 250kg batch, safety procedures and their maintenance of the plant. The successful bidder shall depute skilled technical personnel for operation of units, limited to 10 nos. of successful trials after commissioning.</p> <p>(i) Bidders may visit the site if they feel necessary during working days from 10 am to 5pm.</p> <p>(j) The bidder shall mention the make of equipment in their quotes.</p> <p>(k) The work of supply , erection, integration, installation, and commissioning of Part A, Part B and Part C needs to be done by a single bidder. Any bidder not quoting for any of the Part/ Lot will not be considered for evaluation purposes and will be summarily rejected .</p> <p>(l) Equipment design and engineering shall incorporate adequate safety features (as per applicable specifications of respective installation as well as Health, Safety and Environment Codes& Standards applicable for the subject project) to provide protection to</p>

	<p>operating personnel, equipment and environment.</p> <p>(m) If during the execution of works, it is found that there is interference with other facilities/ structures, the Bidder shall revise his design/ detailed drawings to clear the interference and shall provide all necessary measures for the safety of structures under construction. No claim in terms of cost or relaxation in time shall be entertained for any redesign, rework and for the safety measures provided.</p> <p>(n) If at any stage of work, any dismantling or modification or relocation of any facilities is required to be done to complete the work , the same would be in bidder's scope, which should be done by the bidder at no extra cost or time implication to the CSIR-NML. All such changes will be executed only after the proposed drawings and work plan are approved by the CSIR-NML.</p> <p>(o) Any specific hardware/ item/ etc. required as indicated for completion of building but not listed elsewhere in this specification or its enclosures, shall be deemed to be included in the basic price quoted by the bidder. Also, all mounting hardware/ accessories/ fittings etc. required for above and the E&C of the PEBs shall be deemed to be included in the basic price quoted by the bidder. Bidder, at no point of time, shall be eligible to raise any extra claim in this regard.</p> <p>(p) The supplier shall not assign, in whole or in part, its obligations to perform under the contract, except with the purchaser's prior written consent. The supplier shall notify the purchaser in writing of all the sub – contracts awarded under this contract if not already specified in the bid. Such notification, in the original bid or later, shall not relieve the supplier from any liability or duties or obligation under the contract.</p> <p>(q) Engineering, procurement and construction of the entire plant will be the responsibility of the single qualified bidder.</p>
Chapter 3	<p>Delivery schedule</p> <p>Since time is the essence of this prestigious activity, the successful bidder has to strictly adhere to the time line of delivery of the respective items. Bidders have to provide the broad delivery schedule for the sub-activities of each of the items.</p> <p><i>The total duration of this Turnkey mode activity for PART A, PART-B and PART-C including erection, integration, installation and commissioning shall be completed in all respects within 12 months from the date of order placement. Bidders shall furnish the delivery schedule as per table below.</i></p>

Delivery Schedule

Sl no		WORK ELEMENT	Time line From - To (Months)
1.	Design, Supply, Erection of Pre-Engineered industrial Building (PEB) to house the Pilot Plant equipment and other utilities and facilities.	(a) Civil works related to Superstructure Pre-Engineered building : PART-B / LOT-1 (As per ACTIVITY-1; Refer. Section 7.1) (b) Sub-Structure (Civil works related to Sub-structure) : PART-B / LOT-2 (As per ACTIVITY-1; Refer. Section 7.1)	

		(c) Electrical Installations and supplies : PART-B / LOT-3 (As per ACTIVITY-2; Refer. Section 7.2)	
2.	Design, Supply, Erection and commissioning of 5T EOT crane for the above said Pilot Plant	Installation of EOT crane : : PART-C / LOT-1	
3.	Detailed design, Supply, Erection and commissioning of the Pilot plant equipment along with all accessories and utilities.	(a) Supply of Vacuum induction furnace : PART-A / LOT-1	
		(b) Supply of Air induction furnace : PART-A / LOT-2	
		(c) Supply of melt spinning system with accessories: PART-A / LOT-3	
		(d) Supply of mandatory spares	
		(e) Installation	
		(f) Commissioning	

Table 2.21.1 Payment Terms

The payment mode to the successful bidder qualifying as per the lowest quote in totality for the items PART-A, PART-B, PART-C and Mandatory Spares will be as follows:

(i) **PAYMENT TERMS FOR PART-A:**

PART-A (Refer Items in section 4.6.2)	
LOT No.	Payment terms and Conditions
LOT-1	
1. Vacuum Induction Furnace (Capacity: 250 kg)	(a) 60% payment will be released (against the submission of Tax invoice) on the receipt of material at CSIR-NML in good condition duly certified by I/O and CSIR-NML technical committee for compliance with the Purchase Order. (b) 20% payment would be released after satisfactory installation & commissioning as certified by I/O and CSIR-NML technical committee. (c) 10% payment after Vacuum induction furnace in PART-A has been integrated, installed & commissioned along with PART-A-LOT-3 duly certified by I/O and CSIR- NML technical committee. (d) 10% payment to be released after submission of Performance bank guarantee (PBG) in CSIR format covering upto 60 days beyond warranty period.
LOT-2	
1. Air Induction Furnace (Capacity: 250 kg)	(a) 60% payment will be released (against the submission of Tax invoice) on the receipt of material at CSIR-NML in good condition duly certified by I/O and CSIR-NML technical committee for compliance with the Purchase Order. (b) 20% payment would be released after satisfactory installation & commissioning as

	certified by I/O and CSIR-NML technical committee.
	(c) 10% payment after Air induction furnace in PART-A has been integrated, installed & commissioned along with PART-A-LOT-3, duly certified by I/O and CSIR- NML technical committee.
	(d) 10% payment to be released after submission of Performance bank guarantee (PBG) in CSIR format covering upto 60 days beyond warranty period.
LOT-3	
1. Launder / funnel / tundish. 2. Spinning unit 3. Water cooled Copper Beryllium Drum with associated cooling system. 4. Refractory crucible.	(a) 30% payment will be released (against the submission of Tax invoice) on the receipt of material at CSIR-NML in good condition duly certified by I/O and CSIR-NML technical committee for compliance with the Purchase Order.
5. Refractory Nozzle place in crucible. 6. In situ drum surface polishing facility. 7. Off line ribbon Coiling facility. 8. Associated electrical instrumentation and control. 9. Other utilities. a. Compressed Air System b. Water cooling System c. Associated Electrical d. Associated civil work related to equipment foundation and cooling water pump.	(b) 60% payment would be released after satisfactory integration, installation & commissioning of LOT-1, LOT-2 and LOT-3 of PART-A and Trial run as certified by I/O and CSIR-NML technical committee. (c) 10 % payment to be released after submission of Performance bank guarantee (PBG) in CSIR format covering upto 60 days beyond warranty period.
LOT-4	
1. Mandatory spares	(a) 90% payment on supply of spares to be certified by I/O and Technical committee. (b) 10% payment to be provided along with the PBG amount after LOT-1, LOT-2 and LOT-3 of PART-A are installed and commissioned.

(ii) PAYMENT TERMS FOR PART-B:

PART-B (Refer items in section 4.7.0)	
LOT No.	Payment terms and Conditions
LOT-1	
Civil works related to Superstructure Pre-engineered building.	(a) 60% payment of PART-B-LOT-1 to be released after installation of PEB structure and as certified by I/O and CSIR-NML technical committee.
LOT-2	
Civil works related to Sub-structure	(a) 60% payment of PART-B-LOT-2 will be released on satisfactory erection of Sub-structure and as certified by I/O and CSIR-NML technical committee.

	(b) 30% payment of PART-B: LOT-1 (Civil work) superstructure would be done after completion of LOT-1 and LOT-2 as certified by I/O and CSIR-NML technical committee.
LOT-3	
Electrical installations for the Industrial Shed	(a) 60 % payment after receipt of electrical materials as certified by I/O and CSIR-NML technical committee.
	(b) 30 % payment after electrical installations and certified by I/O and CSIR-NML technical committee.
	(c) 30% payment of PART-B-LOT-2 (Civil work) substructure would be done after completion of LOT-1, LOT-2 and LOT-3 of PART-B as certified by I/O and CSIR- NML technical committee.
LOT-4	
Performance Bank Guarantee (PBG) for LOT-1, LOT-2 and LOT-3 of PART-B.	10% for LOT-1, LOT-2 and LOT-3 of PART-B would be released after submission of Performance bank guarantee (PBG) in CSIR format covering the period upto 60 days beyond warranty period.

(iii) PAYMENT TERMS FOR PART-C:

PART-C (Refer items in section 4.8.0)	
LOT No.	Payment terms and Conditions
LOT-1	
Supply of 5T EOT crane	(a) 60% payment will be released (against the submission of Tax invoice) on the receipt of material at CSIR-NML in good condition duly certified by I/O and CSIR-NML technical committee for compliance with the Purchase Order.
	30% payment would be released after satisfactory installation & commissioning as certified by CSIR-NML.
	10% payment to be released after submission of Performance security in CSIR format covering upto 60 days beyond warranty period.

***Loading/Unloading/shifting of all items as per Part-A, Part- B and Part- C at site and consequent damages, etc. , if any will be the supplier's responsibility and will be covered by him.**

CHAPTER 3

(To be filled by the bidder and enclosed with the Technical Bid)

SCHEDULE OF REQUIREMENTS:

The Schedule of Requirement must clearly specify **the time frame required (Schedule) for delivery of goods and services to be completed** by the bidder (in reference to Scope of Supply given in Chapter-4) if the Contract is awarded for the offer / proposal submitted by the bidder in response to this Tender.

A) Delivery Schedule:

Sr. No.	Brief Description of Goods and Services	Quantity & Unit	Delivery Schedule

Period of delivery shall start from : _____

B) Term of delivery / Delivery Term :

Goods from Abroad

Goods from India

C) Time frame required for conducting installation, commissioning of the equipment, acceptance test, training, etc. after the arrival of consignment or before dispatch of equipment:

Sr. No.	Activity	Time Frame
1	Site Preparation (if required)	
2	Installation & Commissioning	
3	Acceptance Test	
4	Training	

Place : _____

Signature of the Bidder : _____

Date : _____

CHAPTER 4

***Technical
Specifications and
Details of
Amorphous Electrical Steel (AES) Production
Pilot Plant***

Sl. No.	Content	Page No.
4.1.	Introduction	46
4.2.	Broad Process	46
4.3.	Scope of the Work	46
4.4.	Battery Limit	47
4.5.	Location of the Pilot Plant and ambient conditions	47
4.6.	PART-A: Design, fabrication, supply, erection and commissioning of equipment for Amorphous Electrical steel production.	47-52
4.7.	PART-B: Design, fabrication, supply, erection and commissioning of Pre-Engineered Industrial shed with Sub and Superstructure including site development	53-63
4.8.	PART-C: Supply erection and commissioning of 5Ton EOT Crane	63-67
4.9	Preferred Make list	67-70
4.10	Fig-1a : Scheme of the Amorphous Electrical Steel Production Process	71
4.11	Fig-1b: Scheme for pouring of the alloy melt and melt spinning	72
4.12	Fig-2a : Site-Map	73
4.13	Fig-2b : Site-Map	74
4.14	Fig-3: Tentative Layout of Plant	75
4.15	Fig-4 : Tentative Electrical SLD	76

4.1.0 Introduction

Amorphous Electrical Steel (AES) is primarily used as core of transformers which enhances the transformer efficiency. The typical material of AES is an alloy of iron with boron, silicon, and phosphorus in the form of thin (e.g. 20-25 μm) sheets. These materials have high magnetic susceptibility, very low coercivity and high electrical resistance. Thus lowering the transformer core loss, enhances the efficiency. These iron based alloys are produced through melt spinning route with high cooling rate to ensure amorphous structure. The basic process includes alloy preparation, ingot casting, re-melting, foil casting and winding.

The present work is envisaged to set up a Pilot Plant for manufacturing thin (20-25 μm) foil / ribbon of 100 mm width and surface roughness of (Ra) 0.5 micron. The capacity of the pilot plant will be of 250 kg batch size. This Pilot Plant will be set up in one of the premises of Large Scale Testing Facility area of CSIR-National Metallurgical Laboratory, Jamshedpur. The location of this LSTF area located at Nildih, Jamshedpur

4.2.0 Broad Process

In the present work, the iron-based alloy for production of wide AES ribbon will be prepared using commercial iron scrap (low carbon content), ferro-boron and ferro-silicon as the raw materials. The master alloy will be prepared with a desired composition in a **Vacuum Induction Melting (VIM)** furnace, wherein the peak temperature for melt is expected to be as high as 1600 $^{\circ}\text{C}$. This VIM should have the bottom gas purging facilities along with raw material charging port to achieve desired composition of the alloy. The melt will be subsequently poured into ingot moulds. Each ingot can weigh in the range of 20 – 50kg.

The prepared ingot will be re-melted in air induction furnace at a temperature range of 1100 – 1400 $^{\circ}\text{C}$. The induction melting furnace should have hydraulic tilting system to pour the melt into an **tundish assembly** fitted with a replaceable **nozzle**. This nozzle will have a desired opening/slit geometry. The re-melted alloy will be poured through tundish assembly on a water cooled copper / copper-beryllium drum rotating at a peripheral speed of about 25 - 50m/sec. The molten metal so poured on the rotating drum will cast into thin amorphous steel foil/ribbon due to high cooling rate (10⁶ $^{\circ}\text{C}/\text{sec}$) of the molten metal. Uninterrupted controlled pouring of molten alloy need to be ensured on the rotating drum to produce continuous thin foil/ribbon. An inert gas / air scrapper will be suitably placed to detach the AES ribbon from the rotating drum. The continuous ribbon so formed will be preferably coiled online or this ribbon may be coiled offline. The coiled ribbon will be annealed in a magnetic field to achieve desired magnetic / electrical and other properties. The annealing will be performed at a controlled environment and temperature profile with a peak temperature of 450 $^{\circ}\text{C}$.

In above process, the width of nozzle slot, drum-nozzle gap (distance between nozzle slot and cooling drum surface), speed of cooling drum and ferrostatic melt head are the primary factors governing the thickness, continuity and quality of AES ribbon. For process flow diagram refer fig-1a. The scheme of the process is shown in fig-1b.

Suitable space / bins will be allocated within this industrial shed for raw materials and both the intermediate and final product. The schematic of the Plant is shown in the sketch fig 2a and 2b. Tentative plant layout is shown in fig-3.

Typical composition master alloy for AES

The composition range of the master alloy can be

$\text{Fe}_x\text{Si}_y\text{B}_z$ (wherein x is 78-82 at %, y is 8 -10 at % and z is 10-14 at %) 92Fe-5Si-3B may be typical composition in wt %.

4.3.0 Scope of the Work

PART-A: Detailed design, Supply, Erection and commissioning of the Pilot plant equipment along with all accessories and utilities.

PART-B: Design, Supply, Erection of Pre-Engineered Industrial Building (PEB) to house the Pilot Plant equipment and other utilities and facilities.

PART-C: Design, Supply, Erection and commissioning of 5T EOT crane for the above said Pilot Plant

The above activities need to be taken up on turnkey mode. The work description indicated may not be exhaustive for complete and successful completion of the activities in all respect. Mere execution of work furnished in the tender document does not absolve the successful bidder for proper completion of the work in all respect. They shall ensure accomplishment of all the activities necessary for completion of the work in all respect with an objective to produce AES ribbon of 20-25 μm thickness and 100 mm width with surface roughness of (Ra) 0.5 micron. The capacity of the pilot plant will be of 250 kg batch size.

4.4.0 Battery Limit

This Pilot Plant will be set up in one of the premises of Large Scale Testing Facility area of CSIR- National Metallurgical Laboratory, Jamshedpur. The location of this LSTF area located at Nildih, Jamshedpur. The location is marked in fig.2a. The successful bidder needs to execute the job primarily as per the tender specifications including site development. They have to supply all necessary materials including erection, commissioning consumables (including raw materials for commissioning trials), tools & tackles in all respects etc.

CSIR-National Metallurgical Laboratory will provide adequate electrical power and water at respective single source. Successful bidder has to take MT electrical power (2 numbers 1600 Amps ACB, 415V) from nearby sub-station (Refer Fig:2a) and filtered water from nearby overhead water tower.

4.5.0 Location of the Pilot Plant and ambient conditions

4.5.1 Location: CSIR- NML large scale testing facility, Nildih, Jamshedpur, Jharkhand, India. Nearest railway station: Tata Nagar, About 4 kms from the pilot plant site.
Elevation: 151 metre from MSL. Longitude: 86.203, Latitude:22.805.

4.5.1 Max. Ambient temperature: 50DegC.

4.5.2 Seismic Zone: Zone-II.

4.6 PART-A: Design, fabrication, supply, erection and commissioning of equipment for Amorphous Electrical steel production.

4.6.1 Plant Description

A 250 kg batch pilot plant has been envisaged for production of amorphous electrical steel ribbon/ sheet of 100 mm wide and 20 to 25 micron thickness. An industrial shed has been envisaged to house the plant equipment. A tentative layout of the pilot plant along with utilities and office and laboratory has been indicated in fig-3. The master alloy will be prepared with typical raw materials as ultralow carbon iron, ferroboron and ferrosilicon in a 250 kg batch vacuum / inert induction furnace (A). The molten master alloy will be casted in thin slab of maximum 50mm thickness in vacuum / inert atmosphere. The cold master alloy slab will be broken into desired size of pieces manually for remelting. These broken master alloy pieces are remelted in 250 kg induction furnace(B) as shown in fig-1b.The remelted master alloy is poured in to melt reservoir(C) and subsequently into crucible (D) through launder / funnel. The crucible (D) with nozzle (E) is placed inside a box furnace (F). The melt from the crucible is pressure / gravity poured on the rotating water cooled drum (H) through a precise slit refractory nozzle opening. The melt gets rapidly quenched when it comes in contact with the water cooled drum rotating at a preset speed. Ribbon / sheet (G) is formed in this quenching process. The ribbon / sheet is collected and coiled offline.

This plant will be facilitated with handling system like 5T EOT crane and other necessary utilities. The list of the major equipment is indicated below:

4.6.2 Major Equipment list

- (a.) Vacuum Induction Furnace (Capacity: 250kg)
- (b.) Air Induction Furnace (Capacity: 250 kg)
- (c.) Launder / funnel /tundish.

- (d.) Spinning unit
 - I. Water cooled Copper Beryllium Drum with associated cooling system.
 - II. Refractory crucible.
 - III. Refractory Nozzle place in crucible.
 - IV. In situ drum surface polishing facility.
- (e.) Off line ribbon Coiling facility.
- (f.) Associated electrical instrumentation and control.
- (g.) Other utilities
 - i. Compressed air system
 - ii. Water cooling System
 - iii. Associated Electrical
 - iv. Associated civil work related to equipment foundation and cooling water pump.

4.6.3 Broad Specifications of Equipment

4.6.3.1 Vacuum Induction Melting Furnace:1No

Purpose: Required to prepare the master alloy for Amorphous Electrical Steel from commercially available raw materials.

Suggested Specification

- a. Furnace Capacity : 250 kg
- b. Temperature : 1500°C to 1600°C
- c. Temperature measurement : Dip type thermocouple for liquid melt temperature upto 1600°C,
- d. Vacuum range : 10^{-3} m.bar.
- e. Ingot casting facility : Tilting of crucible for casting into
slabs
50mm
casting
of thickness maximum
in vacuum. **Bottom pouring facility optional.**
- f. Electrical control with PLC, auto/manual vacuum controller, PC based SCADA, digital temperature indicator etc for automatic and manual operation. Control console with safety interlocks. Details in section 6.9.

Bidder to Specify

- a. Overall size of the furnace.
- b. Vacuum chamber door: Top or side.
- c. Number of raw materials charging ports.
- d. Type of vacuum gauges.
- e. Configuration of vacuum pumps with size and ratings
- f. Vacuum Induction furnace specifications
 - I. Variable Power
 - II. Frequency
 - III. Refractory lining of the crucible
 - IV. Material of construction of Shell
 - V. Bottom pouring arrangement
 - VI. Raw material charging arrangement
 - VII. Arrangement of sample collection during melting
 - VIII. Arrangement of melt temperature measurement system including transducer
 - IX. Cooling water requirement.
 - X. Type, size and no. of Moulds for casting.

4.6.3.2 Air Induction Furnace: 1 No

Purpose: Required to re-melt the master alloy prepared in vacuum induction furnace.

Suggested Specification

- g. Furnace Capacity : 250 kg
- h. Temperature : 1100°C to 1600°C
- i. Temperature measurement : Dip type thermocouple for liquid melt temperature upto 1600 °C,
- j. Liquid melt tapping : Lip pouring into the resistive heating melt reservoir
- k. Reservoir Ladle tilting arrangement : Hydraulic

Bidder to Specify

- a. Variable Power
- b. Frequency
- c. Refractory lining of the crucible
- d. Material of construction of Shell
- e. Lip pouring arrangement
- f. Arrangement of melt temperature measurement system including transducer
- g. Cooling water requirement.
- h. All associated power pack with control details

4.6.3.3 Crucible

Purpose: Pressurised crucible fitted with nozzle having desired dimensions controls the melt ejected onto the rotating water cooled drum. The melt ejection rate is controlled through a constant melt level in crucible and additional air / inert gas pressure.

Suggested Specification

- a. Crucible type : Replaceable crucible
- b. Discharge arrangement : a suitable nozzle with slit to be fixed at the bottom of the crucible

Bidder to specify

- a. Arrangement for melt level control at accuracy level 5mm or lower.
- b. Type of level controlling sensor.
- c. Crucible material and size
- d. Nozzle material
- e. Arrangement for fixing nozzle to crucible for replaceable nozzle.
- f. Arrangement for fixing crucible to box furnace, launder / funnel. An arrangement drawing may be provided.

4.6.3.4 Nozzle

Purpose: To guide the melt through the slit of the refractory nozzle at a precise geometry over the spinning drum to get the rapidly quenched continuous ribbon / sheet.

Suggested Specification

- a. Nozzle size : With various slit length and slit width for producing ribbons of 50 to 100 mm width

Bidder to specify

- a. Nozzle material
- b. Nozzle availability

4.6.3.5 Water cooled spinning Drum

Purpose: Rapid quenching of the melt to get ribbons / sheet which required high cooling rate of 10^6 K/sec. To achieve such cooling rate a rotating water cooled Copper (may be alloyed with low Beryllium content for wear resistance without much compromising with thermal conductivity) drum is envisaged having a peripheral speed of 20 - 50m/sec. Water cooling of the drum should be sufficient to achieve

amorphous ribbon / sheet.

Suggested Specification

- a. Diameter of the Drum : ~750mm(indicative)
- b. Width of the drum : 500mm or more
- c. Drum rpm : 600 to 1000rpm (continuously selectable)
- d. Drum cooling : Internal water cooling
- e. Dynamic balancing of the drum. : Allowable vibration: 0.010 mm(Indicative).
- f. Transmission :Belt
- g. In-situ drum grinding / polishing attachment along with grinding / polishing tools

Bidder to Specify

- a. Composition of the Copper or Copper Beryllium drum
- b. Thermal conductivity and hardness of the drum
- c. Drum diameter, surface finish
- d. Internal cooling arrangement : Schematic drawing
- e. Drum support bearing type
- f. VVVF Drive rating
- g. Internal water cooling scheme of drum

4.6.3.6 Utilities requirement

- a. Water cooling System
- b. Compressed air system
- c. Associated Electrical
- d. DG Set
- e. Associated civil work related to foundation of equipment and cooling water pump

4.6.3.6.1 Cooling water pumps & water cooling System

Purpose: Cooling arrangement for vacuum induction, air induction furnace, melt spinning unit and other auxiliaries. Two dedicated cooling arrangement system are envisaged, one for melt spinning water cooled drum and other for rest of systems. Each of the cooling system have one operating and other standby pump. In the event of power failure, the water cooling circuit for both the cooling system should be connected to existing overhead water tower.

Suggested Specification

- a. Pump motors : Pump rating should be sufficient to ensure a positive pressure in drain line.
- b. Capacity : 100 m³ / hr
- c. Delivery pressure : 0.7 MPa(Indicative)

Bidder to specify

- a. Suitable Pipe lines, valves, strainer to be provide

4.6.3.6.2 Compressed Air system

Purpose: The compressed air system shall be sufficient to cater the operation need of the plant.

Bidder to specify

- a. Motor capacity, Air tank capacity, accumulator capacity (if any), tank pressure.

4.6.3.6.3 Associated Electrical

All electrical required for complete supply erection and successful commissioning of the plant shall be in the supplier's scope.

Transformer for Control Supply:

Depending on the furnace power & control voltage requirement, the same needs to be selected. All specifications of distribution panel will stand applicable.

LT Motors:

Energy efficient type motors (IE2) will be supplied as per latest IS-12615-2011. VVVF drive

Panel with integrated converter transformer for water cooled Drum:

ABB/SIEMENS make VVVF drive along with suitable capacity motor needs to be installed as per process requirement. Panel should have MODBUS/PROFIBUS interconnectivity for interfacing with plant control system.

4.6.3.6.4 DGSET

80KVA silent DG set needs to be provided for the plant. Details in section 7.2.4.

4.6.3.6.5 Associated civil work related to foundation of equipment, cooling water pump, technological structure, etc.

All civil related equipment, accessories, utilities etc., required for complete supply erection and successful commissioning of the plant shall be in the supplier's scope.

4.6.4 Technological structure and platform

The induction melting chambers should be provided with mounting support made of welded mild steel structure. This structure should have a steel platform on the top and will have steps for climbing onto the platform for operation, observation and maintenance. The platform should be provided with necessary railings for safety purpose. The steel support structure should have facility for positioning of re-melting furnace and melt reservoir over the box furnace and melt spinner. The steel structure should be primer coating and painted.

4.6.5 Bins for Raw Materials and product

Suitable 5 No. bins shall be supplied for raw materials storage. These bins shall be fabricated from steel 3 mm sheet with stiffeners etc. of about nominal capacity of 1 cubic meter.

4.6.6 Instrumentation and Control

Purpose : A state of the art instrumentation and control system are envisaged for the above pilot plant. The respective control logics for major equipment are indicated below:

4.6.6.1 Vacuum Induction Furnace (Capacity 250kg)

- a. Power and Induction frequency control to achieve desired melt temperature. Display of frequency, voltage, current and melt temperature on the control panel.
- b. Control of vacuum to the desired level and display of vacuum in control panel.
- c. Instrumented raw material charging system for charging raw materials in furnace in vacuum / inert atmosphere.
- d. Instrumented casting of melt.
- e. Necessary safety features for No / less flow of cooling water.
- f. Fail safe protocol shall be incorporated.

Note : A single control panel is envisaged for total operation of the furnace.

4.6.6.2 Air Induction Furnace (Capacity: 250kg)

- a. Power and Induction frequency control to achieve desired melt temperature. Display of frequency, voltage, current and melt temperature on the control panel.
- b. Instrumented pouring of melt.
- c. Necessary safety features for No / less flow of cooling water.
- d. Fail safe protocol shall be incorporated.

Note : A dedicated control panel for operation of air induction furnace.

4.6.6.3 Melt Reservoir with resistive heating and bottom pouring.

Control of temperature in the box furnace through PID controller and display of temperature.

Note: All controls and displays shall be housed in the control panel for air induction furnace.

4.6.6.4 Spinning unit

4.6.6.4.1 Water cooled Copper Beryllium Drum with associated cooling system.

- a. Control of drum speed through VVVF drive. Display of voltage and frequency.
- b. Cooling water flow measurement system and display. Measurement and display of temperature of cooling water at inlet and outlet of drum.
- c. Water flow switches at outlet of drum. This flow switch shall be interlocked with Alarm system for variable water flow condition.
- d. Online thickness measurement system for the ribbon / sheet along with thickness display.
- e. All pre-determined control variables (wheel rpm, water flow rate, etc) and displays shall be housed in a dedicated local control panel.

Note : All the above control and display shall be housed in the dedicated local control panel of water cooled copper beryllium drum.

4.6.6.5 Off line ribbon Coiling facility

- a. The coiler shall have variable speed drive.

4.6.7 Spares*

4.6.7.1 Mandatory spares:

- a. Water cooled copper or copper beryllium drum and shaft : 02set
- b. Crucible for three ribbon widths (to be decided) : 100 Nos.
- c. Nozzle suitable for three ribbon widths (to be decided): 300 Nos.
- d. Launder/funnel : 10 nos
- e. Thermocouples/Temperature sensors : 02 sets (each)

4.6.7.2 Two year running spares (Optional):

Bidders to provide the detail. (This is not to be taken for price comparison purpose).

(* The supply schedule of the mandatory spares will be decided during the commissioning trials. The supply schedule of two years running spares, if included in the Purchase Order will be decided during the commissioning trials).

4.7.0 PART(B):

Design, fabrication, supply, erection and commissioning of Pre-Engineered Industrial shed with Sub and Superstructure including site development.

Brief Overview

Successful bidder has to build an Industrial Pre-Engineered Building (PEB) to house the above said equipment for AES pilot plant. This building need to be constructed in Large Scale Testing Facility Area, Nildih, of CSIR- National Metallurgical Laboratory, Jamshedpur. Broadly the scope involves Site development, construction of Pre-engineered shed, offices and other facilities (ref. Fig-2a, 2b and 3), utilities and other peripheral work indicated below. All building materials including machineries, tools, tackles, labours, etc. are to be supplied, provided by the successful bidder.

Successful bidder shall also have to take up the site development including demolition of building, development of the area, etc.

The work indicated in Part-B has been classified as Activity-1 and Activity-2 detailed below:

Activity-1: Work description of Civil works associated with both super and sub-structure with respect to Pre-Engineered building and facilities housed in the building as detailed in section 4.7.1

Activity -2: Work description of Electrical installation, supplies with respect to Pre-Engineered building and facilities housed in the building as detailed in section4. 7.2.

4.7.1 **ACTIVITY-1:** Civil Works associated with both Super structure & Sub-structure Pre- engineered building (Figure3&4)

PEB Size: 52.5m Length X 22.5m Width X 9m Eave Height. Applicable

Codes

Designs as per IS 800: 2007.

Loads on the building are applied in accordance with:

IS: 875 -III - 1987 (reaffirmed 1997) Code of practice for design loads (other than earthquake) for buildings and structures.

Hot rolled and Built up sections are designed with:

IS:800-1984 (Code of practice for general construction in steel) Cold

formed members are designed in accordance with:

IS:801-1975 Code of practice for use of cold formed light gauge steel structure members in general building construction.

Welding is applied in accordance with: American

Welding Society (AWS D1.1.2010) Structural

Welding code - Steel.

4.7.1.1 Super structure specifications

4.7.1.1.1 BuildingCondition

Frame type	TCCS (Taper Column Clear Span)
Bay / Column spacing (suggestive)	7 @ 7.5m C/C of Steel Column
Width	22.5m C/C of Steel Column
Width module	PEB
Length	52.5m C/C of Steel Column
Eave from FFL	9m Eave level
Crane rail Height from FFL(suggestive)	7.5m
Roof slope	1:10
Wind bracing	Angle Bracing considered for Roof & Side Walls
Openings at right sidewall	Open up to 3.5 M for brick work & above sheeted.
Openings at left sidewall	Open up to 3.5 M for brick work & above sheeted.
Openings at front end wall	Open up to 3.5 M for brick work & above sheeted.
Openings at back end wall	Open up to 3.5 M for brick work & above sheeted.
Type of Eave	Gutter & downspouts
	<ul style="list-style-type: none"> ➤ All columns considered from FFL of the building. ➤ 2 nos. cage ladders are considered for walk way access. ➤ 0.75m wide walkway with 5.0 mm thick chequered/perforated plate with hand rail support. ➤ 400 mm projection bracket for cable tray considered all around the building & designed for appropriate loading. ➤ Supporting arrangement should have considered for cable tray. ➤ Appropriate crane rail support needs to be provided for 10T EOT crane. ➤ Adequate turbo vents & side ventilators/louvers need to provided. ➤ Provision for natural lighting for operating bay area needs to be provided.

- a. The PEB shall have a steel frame primary structural member. Built-up sections are made from hot rolled plates conforming to ASTM A-572 Gr50 (345 MPa) steel or equivalent. Grade steel. The plates are joined together on one side of the web to flange by a continuous automatic submerged arc welding process to produce the section required. Hot rolled primary structural members and Rod/ Angle bracing shall conform to IS2062 Grade E250Quality.

- b. Built-up sections are made from hot rolled plates conforming to ASTM A-572 Gr50 (345 MPa) steel or eqvt. Grade steel. The plates are joined together on one side of the web to flange by a continuous automatic submerged arc welding process to produce the section required.
- c. Secondary members for Purlins and Girts shall conform to the specification of IS 811 or ASTM A1003-12 made from steel sheets conforming to ASTM A1011-12b Grade 50 having a minimum yield strength of 345 MPa. The minimum thickness of secondary members shall be 3.15 mm. All other miscellaneous secondary members shall have minimum yield strength of 250 M Pa.

4.7.1.1.2 Wall and Roof Panel

- a. Aluminum/ Zinc alloy sheets are 0.47mm nominal thickness, cold roll-formed from a hot rolled coil conforming to ASTM A-792 M, AZ 150 Grade -550 or equivalent. These sheets are hot dipped coated with a 55%Aluminium, 1.5% Silicon and 43% Zinc alloys. ER SL 1750/SS2000/SS2500 sheets are cold roll formed from hot rolled coil conforming to ASTM A 792 M, AZ 150 150 Grade 275 or equivalent. These sheets are hot dipped coated with a 55% Aluminum, 1.5% Silicon and 43.5% Zinc alloys.
- b. Pre-painted sheets are 0.5 mm nominal thickness, coated with a baked silicon polyester finish on top of an Alum/Zinc alloy finished steel sheet (as per specifications of 3.1.5 above). The paint finish film thickness is 20 microns of silicon modified polyester on the exterior face and 5 microns of polyester on the interior face as per ASTM A-792 M, Grade 80 / AS:2728.
- c. Exterior and interior finishes on the roof panel shall be unpainted Aluminum /Zinc alloy coated panel.
- d. Exterior finish coat on the wall panel shall be modified silicone polyester paint with color selected from the standard steel color chart. Interior finish coat of wall panels shall be polyester paint, std grey color.

4.7.1.1.3 Non-Metals

- a. Sky and wall lights are made of translucent white acrylic modified, Ultra Violet stabilized, fiber glass panels (3.5 Kg/ M2 Nominal weight) and also made out from Polycarbonate sheet (2.4 Kg/ M 2 nominal weight) having UV coating and one side embossing. Sky light panels are provided with same coverage as steel panel width with a maximum length of 3250 mm. Profile of light panels matches that of the roof / wall panel.
- b. Closure strips shall match the sheeting profile, and be made of XLPE or similar material.
- c. Adhesive sealing tapes are made of an elastomeric butyl rubber based extruded sealant on silicon release paper. End lap sealant is neutralized silicon sealant.
- d. Fiberglass insulation is as per IS: 8183, 50 / 100 mm thick, with a vapor barrier (foil scrim Kraft/ reinforced white vinyl/reinforced white metalized film scrim Kraft facing). Density shall be not less than 16Kg/m³.

4.7.1.1.4 Rolling Shutters

Rolling shutters shall be manually or electrically chain operated. Rolling shutter shall be made from round type GI slats of 18 gauge thick GI sheet. Top cover shall also be GI. Guide channel, brackets. Angles etc shall be out of MS duly primed with red oxide primer.

Sizes of rolling shutters will be decided during detail engineering. Preferred dimensions are 4500 x5000mm.

4.7.1.1.5 Fasteners

- a. Primary structural connections are made with electro galvanized (silver) high strength bolts Gr. 8.8 steel conforming to ASTM A-325 & IS: 1367 Gr 8.8. Purlins and girts are connected to their supporting members by machine bolts Gr.4.6 steel conforming to IS 1363 electro- galvanized(yellow).
- b. Anchor bolts are made of rods conforming to ASTM F 1554 with a minimum yield strength of 248MPa.
- c. Roof and wall panels are fastened by No.12 carbon steel self-drilling screws mechanically coated with polymer coated finish with an integral washer head to which an EPDM elastomer layer is bonded.

4.7.1.1.6 Paint and Primer

- a. **Painting of Steel Structures**
Primary steel shall be cleaned and painted according to SSPC-PS-7.01-64 T Specification (Steel structures painting council).
- b. **Shop Primer:** One shop primer coat of Red Oxide Zinc Chromate shall be applied with an average dry film thickness of 25 microns on all red steel. Shop primer provides protection for elements while in transit and construction, and is not intended to be for permanent protection.
- c. **Corrosion protection:** Corrosion Protection by primer application should be done as per standard practices and based on the location and will be decided during detail engineering.

4.7.1.1.7 Accessories

(a) Louvers

S-type fixed louvers shall be manufactured out of 0.5 mm silicon polyester coated Galvalume sheet in white colour with insect screen and is supplied in standard modules of 1500 mm wide x 1000 mm high.

(b) Vents

1. Gravity flow Ridge Vents shall be 600 mm throat, in 3000 mm long units manufactured with Bare Galvalume sheet.
2. Turbo vents with FRP base shall be 600 mm throat and should be installed as per requirement near to ridge.

(c) Natural Lighting

Bidder shall ensure that the shed is designed to utilize maximum natural light during the day.

(d) Roof Extension

Sidewalk Roof Extensions shall be 900 mm cantilevered roof members located at the eave and sloped at the same pitch as the main structure roof slope.

End wall Roof Extension shall be 900 mm cantilevered "C" and "Z" sections which are continuous span extensions of the main building end bay purlins and eave struts.

Roof Extensions structural members (except rafters) shall be completely concealed when optional soffit panel is specified.

(e) Fascias & Parapets:

Vertical and Curveline fascia shall be of the bracket mounted type.

Vertical fascia's shall consist of hot rolled "I" section or cold formed "C" section fascia posts supported by a hot rolled section bracket that is cantilevered from the rigid frames columns at side walls and from the end well posts at end walls, with cold formed 200/250 mm deep "Z" and "C" sections as top and bottom girts respectively. An intermediate "C" grit oriented vertically shall be supplied to support valley gutters when required.

Vertical fascias shall project 600 mm from the steel line. The height of the fascia shall vary depending on actual requirements. Fascia cladding shall be of 0.5 mm thick (nominal) pre-painted Hi-Rib panels. Soffit panels and back side panels are provided only when specified.

Curveline Fascia's shall consist of the same type of construction as vertical fascias but shall be supplied with curved steel panels having the same corrugation profile as the HiRib panel and shall be available in three types:

Type-I shall have a circular panel at the bottom of the fascia only. Type-II shall have a circular panel at the top and bottom of the fascia.

Type-III shall be single panel profile curved at the mid height of the fascia.

Parapets

A parapet shall be made from the same construction as the vertical fascia but without the cantilever. The building's wall sheeting shall continue to the top of the parapet.

(f) Trims & Linear Panels

Trims shall be made of pre-painted Al-Zn steel, 0.5 mm minimum thickness. All trims shall be White except for corner trims and fascia trims which shall match the panel colors. Gutters shall be nominal channel made of 0.5 mm Al-Zn steel. Down pipes shall be in 134mm x 93mm in 0.5mm alum/zinc steel pre-painted white. Linear panel shall be 0.5 mm steel Hi-Rib panels pre-painted white. All liner trims shall match the linear panel color.

(g) Foundation & Anchorage

Foundation and horizontal ties and concrete floor slabs shall be designed as per applicable design standard. Design shall be based on job site soil conditions. Anchor bolts shall be set in strict accordance with the requirement. Structural calculations shall be provided.

(h) Doors

Door frames shall be of T-iron frame of mild steel Tee-sections as per DSR-2016 item no 10.13 if not mentioned otherwise. All doors shall be provided necessary fittings like hinges, handles, mortice locks, tower bolts, stopper, hydraulic door closer, etc. of CP brass complete.

(i) Window

Windows shall be grill protected natural anodized heavy duty aluminum and specifically designed for installation on the exterior panels. Window shall be with 5 mm thick Float glass. Windows shall be two track with sliding shutter. Windows shall be with concealed lock and high quality rubber beading. Detailing will be done during detail engineering.

(j) Rain water down comer

As per standard PEB, Downspouts shall be box type nominal 89mmx118 mm made of 0.5mm, pre painted galvanized off white sheet with minimum yield strength of 240 MPa.

(k) Grouting

Cement mortar (1:2) grout with non-shrink additives shall be used for grouting below base plate of column. The grout shall be high strength grout having a minimum characteristic compressive strength of min 30 N/mm square at 28days.

4.7.1.2 Sub-Structure

Foundation work: Foundation of the PEB and Equipment should be designed based on soil test report available with CSIR-NML.

(a) Plain cement concrete

Providing and laying in position plain cement concrete 1:3:6 (1 cement: 3 coarse sand: 6 graded stone aggregate using 20mm nominal size) including shuttering if required all work up to plinth level etc. complete to be done.

(b) Reinforcement cement concrete.

Providing and laying in position machine batched, machine mixed and machine vibrated design mix cement concrete of specified grade for reinforced cement concrete work including pumping of concrete to site of laying but excluding centering, shuttering, finishing and reinforcement. Including Admixtures in recommended proportions as per IS 9103 to accelerate, retard setting of concrete, improve workability without impairing strength and durability as per direction of Engineer-in-charge. M-25 grade reinforced cement concrete by using 410kg of cement per cum of concrete.

(c) Flooring of the Bay and annexed rooms (Ironite Flooring)

It shall consist of an under bed and a topping (incorporating iron particles) laid over an already laid and matured concrete base. Thickness: Unless otherwise specified the total thickness of the finish shall be minimum 50 mm for horizontal surface of which topping shall not be less than 12 mm. While topping shall be of uniform thickness, the under bed may vary in thickness to provide necessary slope. The vertical surface shall project 6 mm from adjacent plaster or other finishes. Necessary cutting into the surface receiving the finish shall be done to accommodate the specified thickness. The hardening compound shall be uniformly graded iron particles, free from nonferrous metal impurities, oil, grease, sand, soluble alkaline compounds or other injurious materials. The type of flooring in annexed rooms is detailed in section 7.1.2(h).

(d) Vitrified Tiles Flooring

The tiles shall be of approved make like Marbonite / Granamite or equivalent and shall generally conform to the approved standards. They shall be flat and true to shape, free from cracks, crazing spots, chipped edges and corners. Unless otherwise specified, the nominal sizes of tiles shall be as under: The tiles shall be square or rectangular of nominal sizes such as: 600 x 600 mm and as directed by the Engineer-in-Charge.

(e) Plinth protection

Providing and laying in position plain cement concrete 1:2:4 (1 cement: 2 coarse sand: 4 graded stone aggregate using 20mm nominal size) for 50-75 mm thick, and 750mm **width** including shuttering if required all work up to plinth level etc. complete to be done.

(f) Brick work

Brick work 230 mm thick should be provided from plinth level up to 3.5meter height. Brick work with F.P.S. bricks of class designation 75 in superstructure above plinth level up to floor level in all shapes and sizes in Cement mortar 1:6 (1 cement: 6 coarse sand) and for Brick work in partition wall 115 mm will be 1:4 (1 cement:4 coarse sand) with plaster. Exterior & interior of this brick work needs to be painted with application of proper primer and synthetic paint.

(g) Anti-Termite Treatment

Anti-termite treatment should be done at different stages during soil excavation, column foundation and wall construction as per standard practice. Applying chemical emulsion in sealed containers as specified with Chlorpyrifos/ Lindane emulsifiable concentrate of 20%.

(h) Annexed Rooms (Refer Fig 2a&2b)

Dimensions for the annexed rooms are attached in figure 2a & 2b. Pump room, Compressor room, Raw material storage, Mechanical Maintenance room, Diesel Generator room, Electrical panel room, Product storage shall be provided with Ironite flooring. Cable trench with trays, RCC foundation, Column, Tie beam and roof with M-25/M-20 grade needs to be provided. 230mm Brick wall up to 3.5m height to be provided. For Office room, Conference Hall, Analysis Lab: Vitrified flooring, RCC foundation, Column, Tie beam and roof with M-25/M-20 grade needs to be provided. 230mm Brick wall up to 3.5m height to be provided. False ceiling to be provided in conference room & Lab with adequate split type AC Units. Glass panel single door will be fitted to each of these rooms. Toilets should have vitrified tiled flooring and wall tiling upto 7 ft. height. Sewage line should be connected with existing sewer line.

4.7.1.3 Site Development and other works:

4.7.1.3.1 Site development including demolishing the existing building and levelling, removing bushes, throwing of garbage etc,

Clearing jungle including uprooting of rank vegetation or green bush wood, trees and saplings including surface dressing and removal of rubbish / soil etc, complete. Toe wall needs to be provided for retaining of earth for site development.

4.7.1.3.2 Utility water line, sewer line, storm water drain.

Utility water lines and sewer lines, storm water line to be provided as per requirement. Storm water drain needs to be provided throughout the building periphery and needs to be properly connected to main drain.

4.7.1.3.3 Approach road

Approach road to be developed for Exit and Entry paths for the industrial building.

4.7.1.3.4 Renovation of existing cooling pond

Existing cooling pond needs to be repaired to ensure water circulation to tank.

4.7.1.4 Special Notes:

a) After receipt PO, following documents shall be submitted to NML for concurrence:

1. Structural & Civil design calculations and drawings including STADD.Pro
2. GA drawings along with BOM (for sub-structure, super structure, architectural).

b) Design calculations, checked and certified by supplier (OEM), shall be submitted for approval.

c) Bidder shall supply the structural materials such as columns, rafters, beams, purlins, tie rods, sheets, wall cladding/ roofing, hardware etc to the site as per the approved drawings. Raw materials for steel sections, sheets etc shall be of reputed make such as Jindal Steel and Power, RINL, SAIL, TISCO, JSW Steel, Essar Steel, Ispat Industries, Lloyd Steel Industries. Bidder shall take prior approval from NML for the make prior to proceeding with procurement action.

d) Bidder shall also supply the J bolts/ nuts/washers, alignment plates and other related hardware that are used for positioning and anchoring of the PEB structures to the RCC foundation plinth.

e) All the items shall be supplied directly to the project site.

f) Relevant clauses of "Super structure specifications" section shall be adopted.

g) The following minimum documentation shall be submitted by the bidder during the execution stage of work:

1. All Civil foundation drawings, PEBs GA drgs indicating base plates, anchor bolts connection detail, purlin, roof panels, wall panels, scope demarcation etc.
2. BOM of architectural items with detail of item wise make, model, Quantity etc.,
3. Welding specification charts.
4. Nondestructive Testing specifications.
5. Quality Assurance plan.
6. Painting schedule & procedure (shop painting & site painting)
7. Erection drawings
8. Site storage procedure
9. Testing procedures
10. 'AS BUILT' drawings
11. Any other document, as deemed necessary by CSIR-NML, during detail engineering or erection – commissioning stage.

(h) The Bidder shall take all necessary precautions to protect all the existing equipment, structures, facilities and buildings etc. from damage. In case any damage occurs due to the activities of the Bidder on account of negligence, ignorance, accidental or any other reason whatsoever, the damage shall be immediately made good by the Bidder at his own cost to the satisfaction of the CSIR-NML. The Bidder shall also take all necessary safety measures at his own cost, to avoid any harm or injury to his workers and staff at site. In case a liability arises due to injury or death of any worker/workers at site then the sole liability lies with the contractor (successful bidder/

Supplier).

(i) Building should be designed for a life span of 25 years and warranty to this effect should be provided for 1 year in all aspects.

(j) The Bidder shall accept full responsibility for the completeness and for the faultlessness of all the Civil foundations & PEB as a whole. These shall be executed on the basis of proven and certified design principle and in accordance with the latest state of the art in such a manner that the purpose to be served by the plant is fulfilled in every respect. Standardization of equipment, materials etc. shall be employed in the design. Care shall be taken to ensure safety.

(k) Any specific hardware/ item/ etc. required as indicated for completion of building but not listed elsewhere in this specification or its enclosures, shall be deemed to be included in the basic price quoted by the bidder. Also, all mounting hardware/ accessories/ fittings etc. required for above and the E&C of the PEBs shall be deemed to be included in the basic price quoted by the bidder. Bidder, at no point of time, shall be eligible to raise any extra claim in this regard.

(l) By accepting the contract, the bidder shall be deemed to have accepted the obligation of supplying everything that is necessary for the purpose mentioned above, regardless of any omission in the specification or on the drawings for the fulfillment of completion of the Civil infrastructure package.

(m) Even though, the requirements are specified in detail to the extent possible, bidder to apply good engineering practices in the design, selection of equipment, manufacturing, procurement, transportation, fabrication, painting, erection, inspection & testing, commissioning of package etc., wherever same is not clearly spelt out.

(n) The design information, specifications and drawings indicate the "Minimum" requirements and are intended to enable Bidders to ascertain the extent of the work involved. Bidders are expected to supplement the information included in this specification as required and submit a comprehensive bid.

(o) PEB structure should be essentially from the reputed brand makes of BLUESCOPE/ INTERARCH/KIRBY.

4.7.2 ACTIVITY -2: Electrical Items for Utilities and other facilities within the battery limit

The Scope of supply for following electrical items in lot which generally includes the following shall be in line with the below specifications:

4.7.2.1 Plant Electrical Basis

- (a) Low voltage: 415V +10%/-10%, 3-phase, 4 wire system, Fault current level: 50 kA for 1 sec.
- (b) Frequency: 50 Hz + 5%
- (c) PLC / valve control/ IO power supply 24VDC
- (d) UPS output power supply 220V AC/ 110 VAC
- (e) Plant lighting voltage: 240 V, 1-phase, 2wire
- (f) Welding sockets: 415 V, 3-phase, 3wire
- (g) Solenoid valves: 24 V DC / 110 VAC
- (h) Motor heaters: 240 V AC,1-phase
- (i) Motor control circuits & 415V AC Switchgear: 110 V AC,1-phase
- (j) Control voltages for Medium high-voltage switchgear: 110 VDC
- (k) Control supply for Sequence Control & Field Devices 220V AC / 110V AC 24/110 VDC

4.7.2.2 Distribution boards and Control Centers

- (a) 0.415 KV LT distribution Boards/ PCC (Power control center)
- (b) MCC (Motor Control Center)
- (c) Power Distribution Board.

4.7.2.2.1 Specifications for boards and control centers

- a. The low-voltage switchgear will be PCC / MCC of totally enclosed, self-supporting, floor mounted, compartmentalized, single front type construction.
- b. The switchboard will be a sheet steel-clad low-voltage distribution board with door interlocking facility.
- c. MCC will be of fixed design / Non – Draw out Type.
- d. Conventional MCCs will be provided for SELLER Supplied/Utility equipment.
- e. Control voltage shall be 110VAC.

Technical data

- a) Busbar rating : 1600 A for1MVA
- b) Short circuit capacity : 50 kA for 1 (one)sec.
- c) Type of enclosure : for MCC/PCC/PDB, IP-54 Thickness of panel: 2mm.The power contactors will be operated with 110 VAC, and protected separately for each consumer.
- d) 2 nos. incoming feeders from 2 nos 1600 ACBs located in substation. Supplier has to provide a dedicated PCC panel with 2 nos incoming and 1 no bus couplers of 1600A ACB. One of these ACB will be used dedicatedly for induction furnaces, one for other electrical loads and one no ACB for bus-coupler.
- e) Required no of outgoing feeders will be provided with ACB/MCCB with positive isolation depending on the rating & application. MCCB will be used up to 400Aonly.
- f) Spare philosophy – 1 no. of higher rating, 1 no. of lower rating & 1 no. middle rating are considered as spare in each MCC/PCC. In the case of PCC, 1 no. of commonly used feeder is considered as spare in each bus.
- g) All ACBs shall be of electrically spring charged in addition to manual spring charge facility and of manual draw out type.
- h) All ACB & MCCB shall be provided with series trip with Microprocessor based O/C, SC, Instantaneous & E/F relay with 10% setting.
- i) Main & earth bus bars shall be of Aluminum.
- j) Multifunction meter in PCC (I/C & O/G ACB feeders).
- k) Cable entry should be from bottom.

Quantity and Capacity of supplied electrical panels needs to be decided based on Electro- mechanical load list of plant. Bidders to quote accordingly. All associated electricals needs to be considered.

4.7.2.3 Local Control Station / Push Button Station/ Junction Box

Enclosure shall be of MS sheet with power coated paint. It consists of Normal pushbuttons, EMG pushbuttons, indication lamps (LED), Local/Remote selector switch. IP65 Protection will be provided for LPBS.

4.7.2.4 DG Set with ACDB

80KVA silent DG set needs to be provided for the plant. It has been envisaged that DG set running standalone to take care of emergency lighting, emergency loads of the plant. DG set will include separate AMF panel & Distribution Board. Loading on of the DG sets will be limited to 80% of its rated capacity. Auto start facility during normal power failure shall be available. Shutdown will be manual. Insulation will be Class H temperature rise restricted to class F. Diesel tank Capacity will be sufficient for 1 hrs. running. DG enclosure- IP23. Cooling pump motors, EOT crane, Furnace tilting, melt spin wheel drive, Compressor, shop floor lighting loads are envisaged as Emergency electrical loads.

Capacity of the DG is indicative and needs to be reviewed by the bidder based on Emergency load list of plant. Bidders to quote accordingly.

4.7.2.5 LT Control cables, Special cables (if any), Cable trays & Cabling accessories

From the substation (battery limit), Cable laying needs to be done from the battery source end to plant electrical room through underground. Supplier has to make good the damages done due to underground cable laying. Cable lengths will be decided based on actual equipment floor plan. Supplier to quote accordingly. Cable sizes needs to be calculated with voltage drop criteria.

Supplied cables should be as per IS:1554, part - 1, 1988, IS:3961 (Part-II) – 1967, IS:7098 Part-I & II, IEC-60502. Cabling materials and accessories shall include supporting steelworks, racks, trays, double compression glands, lugs, cable identification tags, pre-cast concrete protective covers, galvanized iron cable markers. Cable markers and identification tags shall be provided at 30 m interval for straight cable runs. Cable laying in ground shall include excavation and back filling of earth. Perforated type cable trays up to 300mm size & Ladder type cable trays for 300mm & above. Gap to be maintained in between Power, Control/Instrumentation Cable trays shall be minimum 300 mm. Control and Instrumentation cables shall be considered in different trays to the extent possible, however Control and Instrumentation will be taken in Single Cable tray where there will be space constraint (If applicable).

4.7.2.6 Shop floor & annexed room Lighting system and others

All lighting system needs to be designed as per illumination system IS: 1554 and other green energy standards applicable as per BEE. The minimum size of the cable for feeding power to SLDB or MCBDB having 32A incomer shall be 4x25 sq.mm of type AYFY/AYY as per IS:1554. Cable size for MCBDB to light fittings shall be 2x2.5sq.mm. or 4x2.5 sq.mm as per the configuration of fittings. The cable type shall be YRY/YY as per IS: 1554. In case of concealed wiring, single core, PVC insulated, stranded copper conductor wire of size 1.5 sq.mm in MS conduit shall be used. For utility sockets, cable size shall be 4sq.mm.

Quantity and type of light fittings will be decided based on equipment layout. Lux levels will be decided during detail engineering based on operational requirement. Supplier to quote accordingly. MLDB, SLDB distribution needs to be approved before supply and installation. Energy efficient smart lighting fixtures and controls to be used for buildings.

4.7.2.7 Air Conditioning, Ceiling fan and exhaust

Air conditioning facility needs to be provided for all closed door offices which are Office room, Conference room and Lab room located beside the bay. Air conditioning facility (Split type AC units) with adequate TR capacity should be provided in line with the requirement. Wall mounted fans for the bay and Exhaust fans needs to be supplied as per calculations of fresh air requirement. Bidders to quote accordingly.

4.7.2.8 Sockets for Welding, Power points, room wise distribution points

All switch boards, distribution sockets, power points, electrical utility requirements etc., will be decided as per actual requirement and floor plan. Bidders to quote accordingly.

4.7.2.9 Earthing & Lightning protection Materials

Length of normal earthing electrode shall be 3-3.5 m. Deep bore earthing (18mtr) will be considered, where ever

required due to space constraint, to achieve the required earthing resistance. Length of each earth electrode shall be as per IS 3043 and approved calculation. The resistance value of substation earthing grid shall be less than one (1) ohm.

Separate electronic earthing shall be considered. Selection of earth strip shall be as per IS-3043. Lightning protection shall be provided as per IS: 2309

4.7.2.10 Statutory and safety items

All Statutory & safety items (like Rubber mats, Danger Boards, Safety charts, First Aid Box) required for charging the substation as per Standard.

4.7.2.11 Special notes:

- (a) Load list needs to be provided for the plant mentioning the KVA requirement for the plant.
- (b) SLD for the Electrical power distribution needs to be submitted for approval.
- (c) Quantity & Capacity of Electrical items based on the above specifications will be decided based on the detail engineering inputs from the supplier. However, approvals for the same needs to be taken prior to supply and installation. As per the plant requirement and existing standards, quantity variation will take place and drawings should be revised based on our inputs for getting our approvals.
- (d) All installation floor plans for electrical distribution panels, cable routing drawings, cables, diesel generator, lighting layout, Earthing & lightning circuits, Control philosophies, P&ID drawings needs to be vetted.
- (e) Needless to specify that quantity of electrical items supplied should meet the plant performance in all aspects. As this is a turnkey job, all kinds of electrical items along with accessories should be supplied as per plant and process requirement to the satisfaction of NML Engineer-In charge. Bidder to quote accordingly.

4.8.0 PART- C: Supply erection and commissioning of 5Ton EOT Crane

A 5T EOT crane is envisage in the pilot plant to handle the raw materials, operation and maintenance of the plant equipment. The successful bidder has to design, fabricate, supply, erect and commission the EOT crane successfully in all respects. A broad specification of the crane is indicated below.

TECHNICAL SPECIFICATION FOR EOT CRANE		
1.	Type :	Double Girder
2.	Type of application :	For lifting and carrying of goods (including hot metal) to height of 8m. Weight approximate 5 ton.
3.	Scope of supply	Design, manufacture, supply, erection and Commissioning of EOT crane
4.	Class of duty:	Class II (medium duty)
5.	Standards:	The crane to be designed in accordance with the latest editions of IS 807 and IS 3177 and other relevant standards.
6.	Location :	indoor
7.	Capacity SWL :	5 tons
8.	Height of lift :	9mtrs.
9.	Span :	22 mtrs
10.	Bay length :	52.5mtrs.
11.	Speeds:	
	· Hoisting / lowering :	5 .0 m/min (approximately)
	· Crosstravel:	16.0 m /min(approximately)
	· LongTravel:	16.0 m/min(approximately)

12.	Bridge Girder:	Double Girder fabricated out of MS in one piece plate as per IS - 2062 and each Girder should have double web plate. Girder Should be strong and rugged to withstand the most severe combination of loads/ stresses under different working conditions The bridge Girder shall be designed to have maximum deflection with an span /900 under maximum overload . Material-Steel weldable grade as per IS 2062
13.	End carriages:	Fabricated out of MS plates of suitable Thickness. End carriages to be fitted with substantial safety stops to prevent the crane from falling and should not Interfere with removal of wheel. Suitable L type jacks to be provided at each end of end carriage for jacking up the crane while changing track wheels/ wheel maintenance and should not interfere with removal of wheel.
14.	Cross travel trolley frame:	Trolley frame to be made in one piece built up of rolled sections and plates to form a rigid structure capable of withstanding stresses. Top of trolley frame should be covered with plates all over except for openings required with Wire ropes, flexible cable for bottom block etc. Trolley frame to be fitted with substantial safety stops to prevent the crane from falling. For parts placed on the trolley, access for maintenance, repair or replacement should be provided. Hand rails of suitable height should be provided on all four sides for safety while carrying out maintenance work.
15.	Cross travel and Long travel:	Shall be double flanged wheels of EN 8 Material, machined and wheels hardened to required hardness, connected to LT assembly directly by means of gear wheel and in case of CT the output shaft of the gear box shall be extended on either side and coupled to CT wheels. The wheels to be mounted on antifriction bearings and shall facilitate easy removal & replacement
16.	Hook:	Shall be Single shank " C " type forged steel Conforming to IS 3815 / IS 5749/ IS560 with spring loaded safety latch mounted on thrust bearing for freely swiveling .

17.	Rope drum:	Machined out of seamless pipe of adequate Thickness with machined grooves for the wire rope. The length/dia. should be sufficient to wind the wire rope in one layer only when the drum is in the fully wound position.
18.	Sheaves:	Sheaves machined out of mild steel with adequate no of grooves to suit the no. of falls.
19.	Gear boxes:	Straight or helical spur gear should be used for all motions (worm, bevel gears should not be used). All gears shall be of EN8 or equivalent, hardened with machine cut or hobbled teeth, metric module only. Totally enclosed type, filled with oil. Gear box should be fabricated out of steel plates of minimum 8mm thickness. Top covers to be horizontal at each shaft centre line and fastened to the top half and can be removed for inspection and repair.
20.	Coupling :	Flexible shock absorbing couplings for connecting motor shaft to gear box shaft shall be used.
21.	Bearings:	Ball and roller antifriction/ friction should be used Wherever necessary grease nipples of standard size to be provided.
22.	Brakes:	Double shoe brakes hinged type, brake drum of forged steel, completely machined. Brake levers, hinge pins etc shall be Of hardened steel. Hoist - Electromagnetic and Hydraulic thruster Brakes -1no.Each CT - Hydraulic thruster brakes - 1 no. LT - Hydraulic thruster brakes - 1 no.
23.	Motor capacity:	Hoist, LT, CT : Bidder to specify (The ratings are indicative which may vary as per design).
24.	Control Panel:	Main control panel made out of MS sheet not less Than 14SWG duly powder coated with double door (IP54) consisting of main contactor, LT & CT contactor of different current rating. The control Voltage should be 110V, A.C with interlock arrangement. All motion shall be operated through V.V.V.F drive of suitable K.W. The crane shall be operated through pendent pushbutton station
25.	Cross travel trailing cable :	PVC sheathed, flexible flat cables with multi Strand copper with festooning arrangement.

26.	Power supply:	Power supply to DSL, motors, control circuit, lighting, etc. shall be as per relevant standards.
27.	Painting:	Complete crane covering structural ,mechanical & electrical parts be thoroughly cleaned of dirt and then shall be painted with 2 coats of red oxide primer followed by 1 coat of synthetic enamel Paint.(Yellow), Drives and electrical parts with grey . After erection and commissioning at site, final coat of synthetic enamel paint. (Yellow), drives and electrical parts with grey shall be given.
29.	DSL guard:	DSL guard to be provided for the wire rope not to come in contact with DSL system.
30.	Rails:	Suitable rails may also be provided.
31.	Spares(Mandatory) :	Spares considered necessary for 2years operation of the crane : Bidder must provide the list of mandatory spares. It will be considered for price comparison.
32.	General:	The following should not be used in any part of the crane bush bearing, combustible material, wood, open gears in any drives. All bolts/nuts except those with Nylon nuts should be of High tensile Grade 12.2 with grip loose nuts or spring washers. All components should be of metric sizes. Defects in materials like factures, cracks Blowholes, laminations, pitting etc. are not allowed. It should be ensured that the crane is manufactured as per the tolerances specified in the standard. Grease nipples to be provided wherever necessary for lubrication. All the bought out items including cables shall be of reputed make only.
33.	Testing at Manufacturer's:	All electrical & mechanical equipments shall be work tested in accordance with appropriate standards

34.	Documentation:	The following documents shall also be submitted along with the supply (5 sets) Material test certificate of all the items electrical, mechanical and structural components. G A drawing (showing elevation, cross section & plan of the crane) indicating clearances, hook approach, lift, wheel base wheel loads with spacing etc, Gear box details of all drives, Circuit diagrams showing wiring of complete crane. Test certificates for all motors, brakes, hook, wire Rope, radiography test for welded parts of girder, end carriage etc. inspection /test reports, of bought out items and maintenance manuals, lubrication charts.
35.	Installation and commissioning:	Installing of trolley rail Erection of bridge girders taping of power from panel at Pilot Plant with an isolation switch. Unloading from the trailer, erection, commissioning and testing of crane as per IS standard is supplier's responsibility.
36.	Two year running spares(optional)	Bidders to provide the list of optional spares.it will not be considered for price comparison .

4.9.0 Preferred Make list

Si no	Item	Make
1.	Vacuum Induction Furnace (Capacity: 250 kg)	Hindhivac/Inductotherm/ or equivalent
2.	Air Induction Furnace (Capacity: 250 kg)	Inductotherm/Electrotherm/ or equivalent
3.	Water cooled Copper or Copper Beryllium Drum	Bidder to specify
4.	Crucible	Bidder to specify
5.	Nozzle	Bidder to specify
6.	Coiler	Bidder to specify
7.	Compressor	Atlascopco/ELGI/
8.	Electrical Panels	L&T/ SIEMENS/ABB/KEPL / Tricolite / Schneider/ SPS (Faridabad)/ or equivalent
9.	Switchgear, Control gear, Starters, Relays	Siemens / L & T / Schneider / ABB / Danfoss / or equivalent
10.	MCCB.	L & T / Siemens / Schneider/ C&S/ or equivalent
11.	MCB.	L & T - Hager/ Le Grand /MDS/Schneider/ or equivalent
12.	Cables.(As per IS)	CCI / Havells./ Finolex/ Polycab/ or equivalent
13.	HRC Fuses	L & T / Siemens/ Schneider/ or equivalent
14.	Indicating Lamps	Schneider/L & T/ Siemens/ or equivalent

15.	Push Buttons	Automatic Electric/Rishab/ or equivalent.
16.	Voltmeters, Ammeters	Kappa/ AE/ or equivalent.
17.	Current Transformers	Siemens / Honeywell / Sauter Race /ABB/ or equivalent
18.	MCB Distribution board / SS Enclosure/ Load line DB	ABB / MDS / L&T / Havell's/Schnider / Siemens/ or equivalent
19.	FRLS PVC insulated copper conductor single core cable	Havell's / Polycab / HPL / Mescab / Standard / KEI/ or equivalent
20.	LED Light fittings	Philips / Osram / Wipro
21.	1.1KV grade, PVC insulated and PVC sheathed heavy duty/XLPE aluminium conductor cables	Havell's/Polycab/HPL/ Mescab/Laser/KEI / or equivalent
22.	VVVF drive	ABB/SIEMENS/ or equivalent
23.	Electric Motor	ABB /C.G /Seimens / Kirloskar/ BBL/ Marathon/ or equivalent
24.	Pipes (MS)	Jindal / TATA /SAIL/ Surya / or equivalent
25.	Butterfly Valves	Audco / L&T/ IVC/ Fouress/ or equivalent
26.	Check Valves /NRV	IVC/ Audco/ L&T
27.	PEB	BLUESCOPE/ INTERARCH/KIRBY/ or equivalent
28.	PUMPS	Kirloskar/ CG/ Beacon/ Mather and Platt/ KSB/Grundfos / or equivalent
29.	PLC Panels	ABB/SIEMNS/HONEYWELL/ROCKWELL/ or equivalent
30.	Split type Air conditioners	Carrier/ Bluestar/Voltas/ or equivalent
31.	Cement	
	(A) White	Birla Plus. J.K White, Nerolac, Berger/ or equivalent.
	(B) Portland	Ultra Tech, Associate Cement Company, Lafarge, Birla. / or equivalent
	Steel	Tisco, Sail, Jsw, ISI Approved Grade. / or equivalent
32.	Ceramic Tiles/ Vitrified Tiles	Kajaria, Nitco, Orient, Somany,Johnson/ or equivalent,
33.	Water Proofing Compound	Pidilite, Sika , Cico/ or equivalent.
34.	Distemper	Berger, Nerolac, Asian, Ici Dulux, Snowcem/ or equivalent.
35.	Red Oxide, Zinc Chromate	Berger, Nerolac, Asian, Ici Dulux, Snowcem/ or equivalent.
36.	Waterproofing Cement Paint	Berger, Ici Dulux,Snowcem, Asian, Nerolac/ or equivalent.
37.	Wall Putty	Berger, Nerolac, Asian, Ici Dulux,Snowcem/ or equivalent
38.	Cement Primer	Berger, Nerolac, Asian, Ici Dulux,Snowcem/ or equivalent
39.	Acrylic Emulsion	Berger, Nerolac, Asian, Ici Dulux,Snowcem/ or equivalent

40.	Premium Acrylic Emulsion	Berger, Nerolac, Asian, Ici Dulux, Snowcem/ <i>or equivalent</i>
41.	Synthetic Enamel Paint	Berger, Nerolac, Asian, Ici Dulux/ <i>or equivalent</i>
42.	FLUSH DOORS (Any Type)	ISI MARKED CRYSTAL, GREEN PLY ,CENTUARY. / <i>or equivalent</i>
43.	Locks	M/S Godrej And M/S Link/ <i>or equivalent.</i>
44.	Floor Springs	M/S Everite, M/S Garnice/ <i>or equivalent.</i>
45.	Hydraulic Door Closer	M/S Hafele India Pvt. Ltd. & M/S Godrej/ <i>or equivalent</i> ,
46.	Block Board, Any Ply Board	M/S Green Ply Industries Ltd, M/S Kitply Industries Ltd, M/S Century Ply Boards (I) Ltd/ <i>or equivalent.</i>
47.	Prelaminated Partical Board Phenol Bonded Exterior Grade Teak Particle Board	M/S Novapan Industries Ltd, M/S Kitply Industries Ltd/ <i>or equivalent.</i>
48.	Prelaminated Partical Board Phenol Bonded Interior Grade Particle Board With Isi Mark.	M/S Kitply Industries Ltd, M/S Novapan Industries Ltd/ <i>or equivalent.</i>
49.	False Ceiling	M/S Armstrong World Industries Ltd, M/S India Gypsum Ltd.
50.	Laminate	M/S Greemlam/ <i>or equivalent.</i>
51.	Cistern	
	(A) Lowdown Pvc Cistern	Parryware/ Hindware/ Seabird/ <i>or equivalent.</i>
	(B) Lowdown Viterous China Cistern Viterous China	Parryware/ Hindware/ Seabird/ <i>or equivalent.</i>
52.	Wash Basin / Laboratory Sink	Parryware/ Hindware/ Seabird/ <i>or equivalent.</i>
53.	Water Closet/Foot Rest	
	A) European Type	Parryware/ Hindware/ Seabird/ <i>or equivalent.</i>
	B) Indian Type	Parryware/ Hindware/ Seabird/ <i>or equivalent.</i>
	C) Orissa Type	Parryware/ Hindware/ Seabird/ <i>or equivalent.</i>
54.	C.P Brass Bib Cock	Omco, Jaquar, Essco/ <i>or equivalent.</i>
55.	C.P Brass Stop Cock	Omco, Jaquar, Essco/ <i>or equivalent</i>
56.	C.P Pillar Cock	Omco, Jaquar, Essco/ <i>or equivalent</i>
57.	Ferrule Brass	Leader / Zoloto/ <i>or equivalent</i>
58.	Cast Iron Pipes And Fittings	As Approved By Isi/ <i>or equivalent.</i>
59.	Valves	

	(A) Gun Metal Valves	Leader/ Zoloto/ L & T/ <i>or equivalent</i>
	(B) Brass Valves	Leader/ Zoloto/ L & T/ <i>or equivalent</i>
	(C) Cast Iron Valves	Leader/ Zoloto/ L & T/ <i>or equivalent</i>
	(D) Stainless Steel Valves	Leader/ Zoloto/ L & T/ <i>or equivalent</i>
60.	Pvc Pipe & Fitting	Prince / Supreme/ <i>or equivalent</i>
61.	Ductile Iron Pipe	M/S Electrosteel / <i>or equivalent</i>
62.	5 Ton EOT Crane	Fafeco/Demag/Kone/Armsell/Jessop/ <i>or equivalent</i>
63.	DG set	Jackson/ <i>or equivalent</i>

NB : If any bidder is not in a position to quote as per the list mentioned above then the matter would be discussed in Pre-bid and if felt necessary CSIR-NML will come out with an amended preferred list wherever required and will post the same on website as final specification. However compliance to the "Make" or definition of an "equivalent" make will be the decision of the Technical committee of CSIR-NML and will be binding on all the quoting firms.

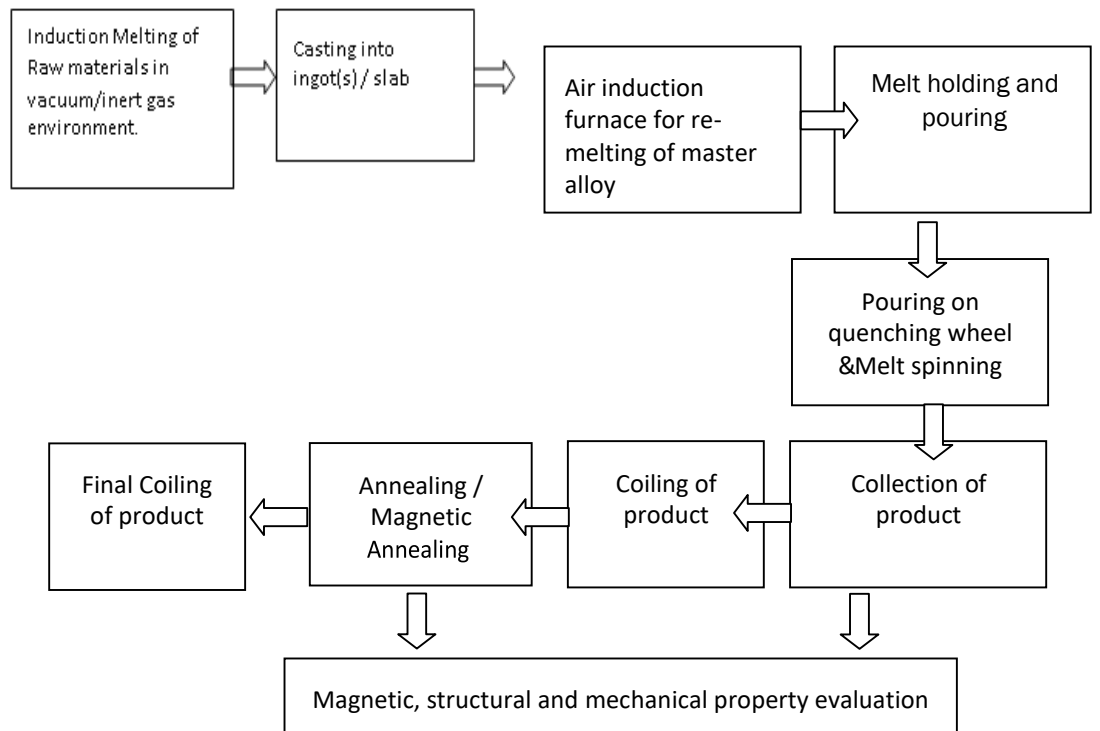

Fig-1a : Scheme of the Amorphous Electrical Steel Production Process

A: Offline master alloy preparation in VIM furnace

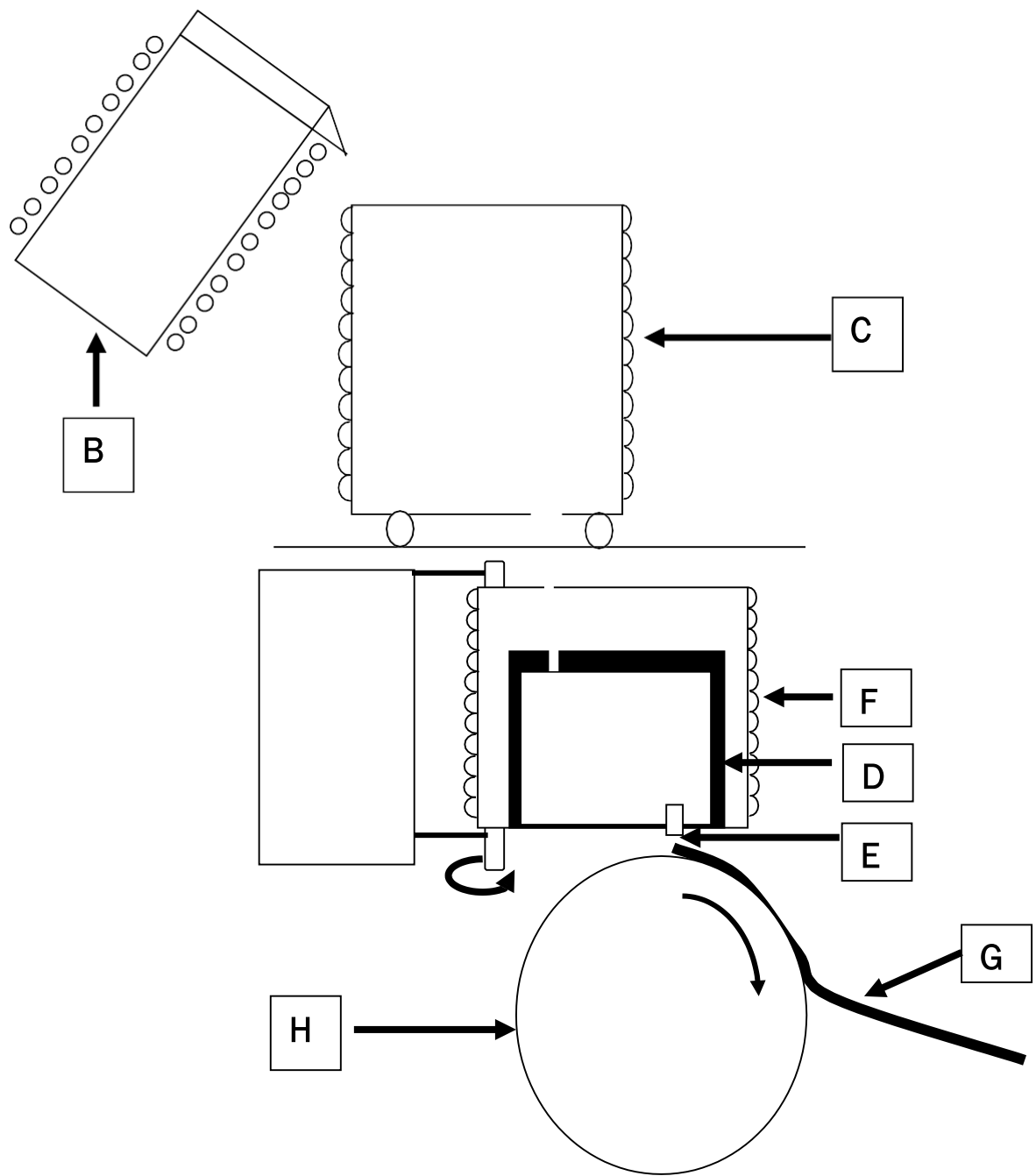

Fig-1b : Scheme for pouring of the alloy melt and melt spinning



Fig-2a : Site-Map

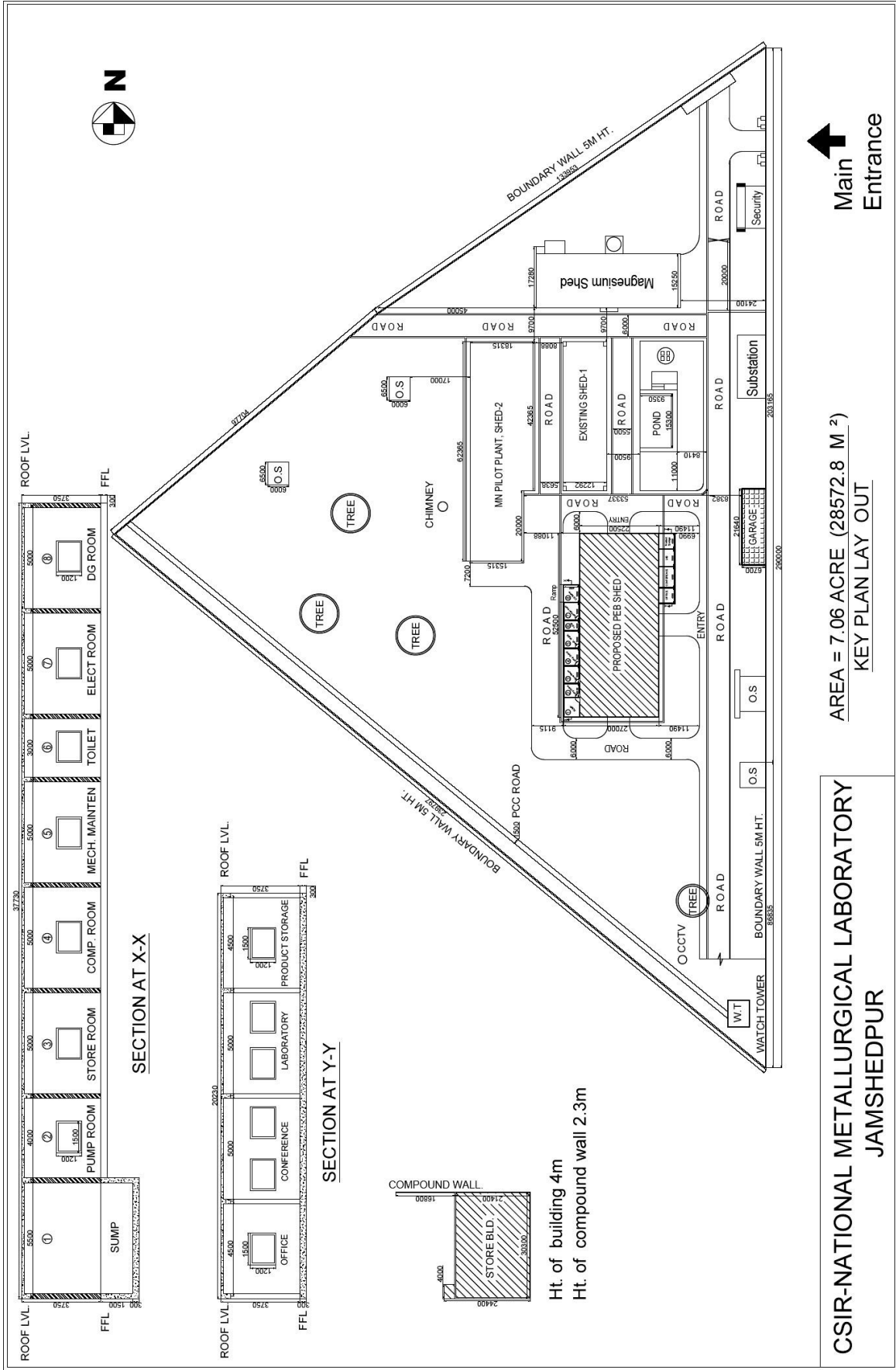

Fig-2b : Site-Map

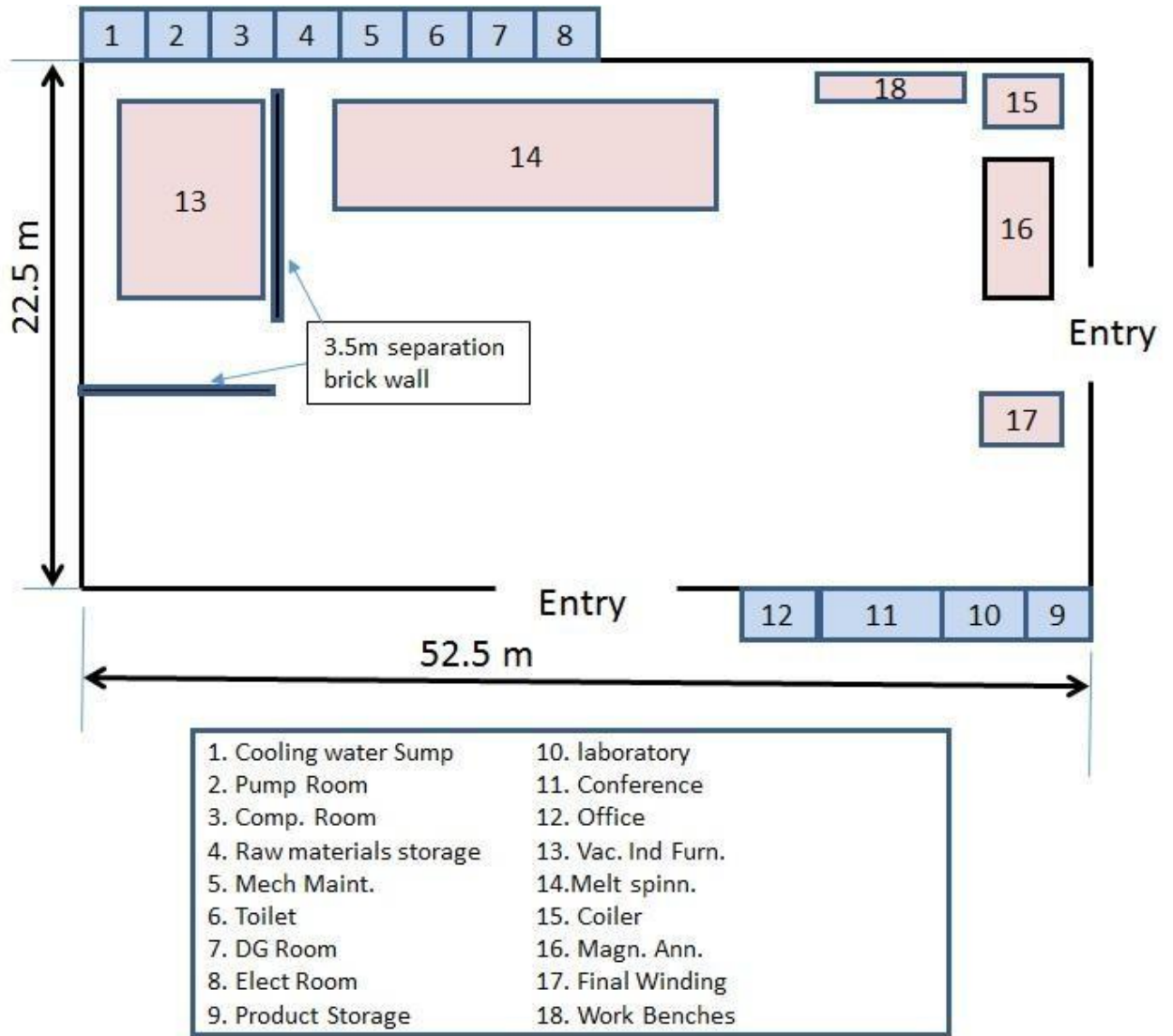

Fig-3: Tentative Layout of Plant

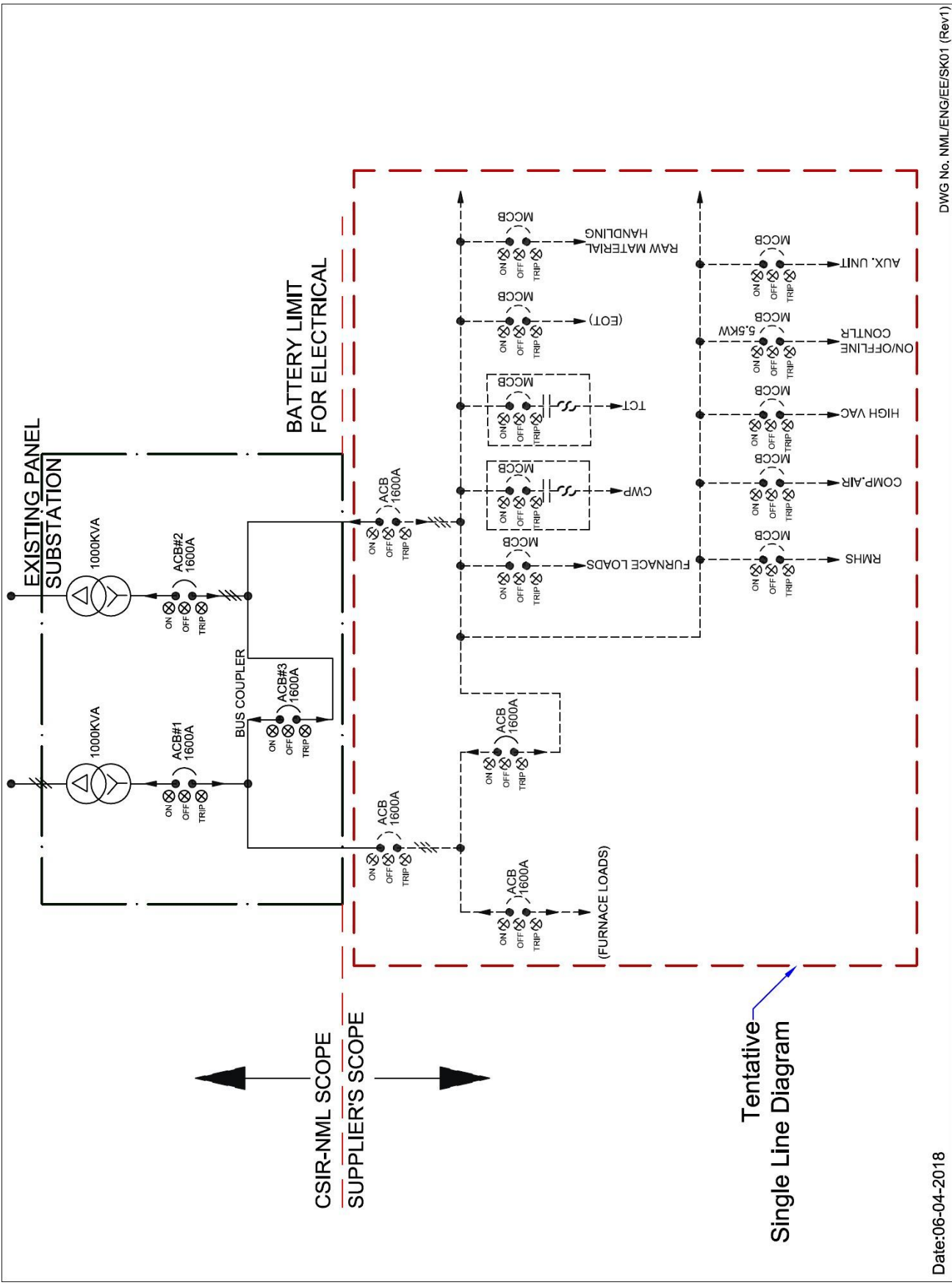

Fig-4 : Tentative Electrical SLD

CHAPTER 5

Eligibility & Qualification Requirements

5.1 Eligibility Criteria

a) **Legal Valid Entity:**

The Bidder shall necessarily be a legally valid entity either in the form of a Limited Company or a Private Limited Company registered under the Indian Companies Act, 1956 or Country of Origin.

Bidder in the form of consortium and Partnership is not permitted.

Copy of Certificate of Incorporation issued by Registrar of firms/companies is to be submitted in support of this criterion.

b) Indian Agent quoting on behalf of Foreign Principal supplier should submit a certified **copy of an Agreement/Memorandum of understanding (MOU)** between both the parties.

c) The bidder shall furnish documentary evidence to demonstrate that the bidder satisfies the bidders' **eligibility criteria**, as mentioned in **ITB Clause 1.1.2** in the form as per **Annexure-K of Chapter- 8**.

d) An **undertaking (self-certificate)** is to be submitted that the Organization has not been blacklisted during last 3 years by any Central / State Government Department/Organization in the form as per **Annexure-L of Chapter- 8**.

5.2 Technical Qualification Criteria

a) The Bidder should be a manufacturer /authorized representative of a manufacturer who must have designed, manufactured, tested and supplied the equipment(s) similar to the type specified in the "Technical Specification". Authorised representative / Indian Agent to submit the **Manufacturers' Authorization Form Chapter-8: Annexure B** with the technical bid.

b) Equipment / System offered must be of the most recent series/models incorporating the latest improvements in design. The models should be in successful operation for at least one year as on date of Bid Opening. The bidder (OEM/Direct Distributor/Dealer) should have supplied and installed during **past 2 years, at least two similar equipment / systems** as mentioned in Chapter-4.

The Bidder should furnish the information on all past supplies and satisfactory performance during past 3 years in the **Performance Statement Form** (Chapter-8, Annexure D). Bidders shall invariably furnish documentary evidence (Client's certificate) in support of the **satisfactory operation of the equipment / system**.

c) Details of Service Centres and information on service support facilities that would be provided after the warranty period (in the **Service Support Form-Chapter-8 Annexure-F**).

d) Foreign bidder/suppliers quoting directly, should submit a letter of Authorisation in favour of Indian Agent/Representative indicating complete address, contact person and validity of Authorization if any along with their technical bid. Foreign bidder/suppliers quoting directly should ensure that adequate and specialized expertise is already available **or** will be made available following the execution of the contract in the Purchaser's country, to ensure that **the support services are responsive and adequate** as per **ITB 1.13.2(c)**.

5.3 Financial Qualification Criteria

a) The Bidders are requested to submit **Audited Balance Sheet** for the **last three financial year** along with Technical Bid.

5.4 Either the Indian Agent on behalf of the foreign principal or the foreign principal directly could bid in a tender **but not both**. However, the offer of the Indian Agent should also accompany the authorization letter from their principal. Further, to maintain sanctity of tendering system **one Indian agent cannot represent two different foreign principals in one tender**.

CHAPTER 6 A

FORMAT FOR PRICE BID for Goods being offered from abroad)

(i) PRICE DETAILS: (Consolidated Price for Part- A, Part- B & Part- C & Mandatory Spares)

Sl.No.	Description of Item	Basic Price	Packing, Forwarding & Handling Charges	FCA / FOB Price	Freight and Insurance Charges up to Kolkata Airport/ Seaport	CIP/ CIF Price
1.	Part- B: Design, Supply, Erection of Pre-Engineered Industrial Building (PEB) to house the Pilot Plant equipment and other utilities and facilities.					
2.	Part-C: Design, Supply, Erection and commissioning of 5T EOT crane for the above said Pilot Plant					
3.	Part- A: Detailed design, Supply, Erection and commissioning of the Pilot plant equipment along with all accessories and utilities.					
4.	Mandatory spares as mentioned as per section 6.7.1					
	*Total cost (SL no. 1+2+3+4)					

***If any item is sourced from India then same may be indicated in Chapter 6B**

(ii) **COST BREAK-UP FOR MAJOR ITEMS in PART-A AND PART-B OF PRICE BID (Goods being offered from abroad)**

(list below is exemplary and not limited to the items mentioned)

Sl.No.		Description of Item	Basic Price	Packing, Forwarding & Handling Charges	FCA / FOB Price	Freight and Insurance Charges up to Kolkata Airport/ Seaport	CIP/ CIF Price
1.	Design, Supply, Erection of Pre-Engineered Industrial Building (Part B) industrial Building (PEB) to house the Pilot Plant equipment and other utilities and facilities.	Superstructure for PEB Industrial shed (PART-B-LOT-1)					
		Civil and Allied site development works for proposed industrial shed(PART-B-LOT-2: Substructure)					
		Electrical allied works for PEB industrial shed (PART-B-LOT-3)					
2.	Design, Supply, Erection and commissioning of 5T EOT crane for the above said Pilot Plant (Part C)	Installation of EOT crane : PART-C / LOT-1					
3.	Part- A: Design, Supply, Erection of Pre-Engineered Industrial Building (PEB) to house the Pilot Plant equipment and other utilities and facilities.	Vacuum Induction Furnace (Capacity : 250kg)(PART-A-LOT-1)					
		Air Induction Furnace (Capacity: 250 kg) (PART-A-LOT-2)					
		Melt Reservoir with resistive heating and bottompouring					

		(PART-A-LOT-3)					
		Spinning unit (PART-A-LOT-3)					
		Water cooled Copper beryllium drum with shaft (PART-A-LOT-3)					
		Mandatory spares (Item wise break-up to be furnished) (PART-A-LOT-3)					
		Installation					
		Commissioning					

iii) TWO YEARS RUNNING SPARES (OPTIONAL) AND EXTENDED WARRANTY (OPTIONAL)

SL no	Description of items	Quantity	Base Price (Inclusive of all except GST)	Taxes	Total price (Inclusive of taxes)
	2 years running spare including main AES equipment including EOT Crane and utilities (items to be quoted item wise) (Not to be considered for price comparison purpose)				

SL no.	Description of head (Extended warranty for PART-A, PART-B AND PART-C to be provided separately)	Base Price (Inclusive of all except GST)	Taxes	Total price (Inclusive of taxes)
	Extended Warranty for first Three years each separately (OPTIONAL) (Not to be considered for price comparison purpose)			

OTHER TERMS

Sr. No.	Approximate weight of the Consignment	Approximate dimensions of the consignment
1		
2	Mode of Shipment	
3	Port of Destination	Final Destination
NOTE:	Agency Commission, if any would be payable only in Indian Rupee as per the Exchange Rate mentioned in the Bill of Entry.	

CHAPTER 6 B

(PRICE BID for goods being offered from India)

(I) PRICE DETAILS: (Consolidated Price for Part- A, Part- B & Part- C & Mandatory Spares)

Sl.No.	Description of Item	Basic Price	Applicable Tax/Taxes on Basic Price (%)	Packing, forwarding, insurance and freight (Lump Sum)	Total Price (FOR CSIR-NML) - Including Taxes
1.	Part- B: Design, Supply, Erection of Pre-Engineered Industrial Building (PEB) to house the Pilot Plant equipment and other utilities and facilities.				
2.	Part-C: Design, Supply, Erection and commissioning of 5T EOT crane for the above said Pilot Plant				
3.	Part- A: Detailed design, Supply, Erection and commissioning of the Pilot plant equipment along with all accessories and utilities.				
4.	Mandatory spares as mentioned as per section6.7.1				
	*Total cost (SL no. 1+2+3+4)				

t

***If any item is sourced from abroad then same may be indicated in Chapter 6A**

(II) COST BREAK-UP FOR MAJOR ITEMS in PART-A AND PART-B OF PRICE BID

(goods being offered from India) (list below is exemplary and not limited to the items mentioned)

SI No	Description of Item	Basic Price	Applicable Tax/Taxes on Basic Price (%)	Packing, forwarding, insurance and freight (Lump Sum)	Total Price (FOR CSIR-NML) - Including Taxes
1.	Design, Supply, Erection of Pre-Engineered Industrial Building (Part B)	Superstructure for PEB Industrial shed (PART-B-LOT-1)			
	industrial Building (PEB) to house the Pilot Plant equipment and other utilities and facilities.	Civil and Allied site development works for proposed industrial shed ((PART-B-LOT-2: Substructure)			
		Electrical allied works for PEB industrial shed (PART-B-LOT-3)			
2.	Design, Supply, Erection and commissioning of 5T EOT crane for the above said Pilot Plant (Part C)	Installation of EOT crane : : PART-C / LOT-1			
3.	Detailed design, Supply, Erection and commissioning of the Pilot plant equipment along with all accessories and utilities. (Part- A)	Vacuum Induction Furnace (Capacity : 250kg)(PART-A-LOT-1)			
		Air Induction Furnace (Capacity: 250 kg) (PART-A-LOT-2)			
		Melt Reservoir with resistive heating and bottom pouring (PART-A-LOT-3)			
		Spinning unit (PART-A-LOT-3)			
		Water cooled Copper beryllium drum with shaft (PART-A-LOT-3)			
		Mandatory spares (Item wise break-up to befurnished) (PART-A-LOT-3)			
		Installation			
		Commissioning			

TDS will be deducted at actuals.		
8	Annual Maintenance Contract / Charges	
	Comprehensive	Non-Comprehensive
Grand Total in Figures		
Grand Total in Words		
OTHER TERMS		
Sr. No.	Approximate weight of the Consignment	Approximate dimensions of the consignment
1		
2	Mode of Shipment	
3	Port of Destination	Final Destination

(iv) TWO YEARS RUNNING SPARES (OPTIONAL) AND EXTENDED WARRANTY (OPTIONAL)

SL no	Description of items	Quantity	Base Price (Inclusive of all except GST)	Taxes	Total price (Inclusive of taxes)
	2 years running spare including main AES equipment including EOT Crane and utilities (items to be quoted item wise) (Not to be considered for price comparison purpose)				

SL no.	Description of head (Extended warranty for PART-A, PART-B AND PART-C to be provided separately)	Base Price (Inclusive of all except GST)	Taxes	Total price (Inclusive of taxes)
	Extended Warranty for first Three years separately (OPTIONAL) (Not to be considered for price comparison purpose)			

CHAPTER 7

Contract Form

Contract No. _____ Date: _____

THIS CONTRACT AGREEMENT is made
the [*insert: number*] day of [*insert: month*], [*insert: year*].

BETWEEN

- (1) The Council of Scientific & Industrial Research registered under the Societies Registration Act 1860 of the Government of India having its registered office at 2, Rafi Marg, New Delhi-110001, India represented by National Metallurgical Laboratories, Jamshedpur (hereinafter called "the Purchaser"), and
- (2) [*insert name of Supplier*], a corporation incorporated under the laws of [*insert: country of Supplier*] and having its principal place of business at [*insert: address of Supplier*] (hereinafter called "the Supplier").

WHEREAS the Purchaser invited bids for certain Goods and ancillary services, viz., [*insert brief description of Goods and Services*] and has accepted a Bid by the Supplier for the supply of those Goods and Services in the sum of [*insert Contract Price in words and figures, expressed in the Contract currency(ies)*] (hereinafter called "the Contract Price").

NOW THIS AGREEMENT WITNESSETH AS FOLLOWS:

01. In this Agreement words and expressions shall have the same meanings as are respectively assigned to them in the Conditions of Contract referred to.
02. The following documents shall constitute the Contract between the Purchaser and the Supplier, and each shall be read and construed as an integral part of the Contract:

(a)	This Contract Agreement
(b)	General Conditions of Contract
(c)	Special Conditions of Contract
(d)	Technical Requirements (including Schedule of Requirements and Technical Specifications)
(e)	The Supplier's Bid and original Price Schedules
(f)	The Purchaser's Notification of Award
(g)	[<i>Add here any other document(s)</i>]

03. This Contract shall prevail over all other Contract documents. In the event of any discrepancy or inconsistency within the Contract documents, then the documents shall prevail in the order listed above.
04. In consideration of the payments to be made by the Purchaser to the Supplier as hereinafter mentioned, the Supplier hereby covenants with the Purchaser to provide the Goods and Services and to remedy defects therein in conformity in all respects with the provisions of the Contract.
05. The Purchaser hereby covenants to pay the Supplier in consideration of the provision of the Goods and Services and the remedying of defects therein, the Contract Price or such other sum as may become payable under the provisions of the Contract at the times and in the manner prescribed by the Contract.

IN WITNESS whereof the parties hereto have caused this Agreement to be executed in accordance with the laws of Union of India on the day, month and year indicated above.

For and on behalf of the Council of Scientific & Industrial Research

Signed : [*insert signature*]
in the capacity of [*insert title or other appropriate designation*]
in the presence of [*insert identification of official witness*]

Signed : [*insert signature*]
in the capacity of [*insert title or other appropriate designation*]
in the presence of [*insert identification of official witness*]

For and on behalf of the Supplier

Signed : [*insert signature of authorized representative(s) of the Supplier*]
in the capacity of [*insert title or other appropriate designation*]
in the presence of [*insert identification of official witness*]

CHAPTER 8

OTHER STANDARD FORMS

Sr. No.	Name of the Form	Annexure
1	Bidder Information Form	A
2	Manufacturers' Authorization Form	B
3	Bid Security Form / Earnest Money Deposit	C
4	Performance Statement Form	D
5	Deviation Statement Form	E
6	Service Support Detail Form	F
7	Bid Form	G
8	Performance Security Form	H
9	Acceptance Certificate Form	I
10	Indemnity Bond	J
11	Eligibility Certificate	K
12	Non Black List Certificate	L
13	Integrity Pact	M

NOTE: The Successful Bidder shall submit Documents with reference to Annexure – H, I & J after Award of Contract as mentioned in Purchase Order.

Bidder Information Form

(a) [The Bidder shall fill in this Form in accordance with the instructions indicated below. No alterations to its format shall be permitted and no substitutions shall be accepted. This should be done of the letter head of the firm]

Date : [insert date (as day, month and year) of Bid Submission]

Tender No :[insert number from Invitation for bids]

01.	Bidder's Legal Name <i>[insert Bidder's legal name]</i>
02.	In case of JV, legal name of each party: <i>[insert legal name of each party in JV]</i>
03.	Bidder's actual or intended Country of Registration: <i>[insert actual or intended Country of Registration]</i>
04.	Bidder's Year of Registration: <i>[insert Bidder's year of registration]</i>
05.	Bidder's Legal Address in Country of Registration: <i>[insert Bidder's legal address in country of registration]</i>
06.	Bidder's Authorized Representative Information Name: <i>[insert Authorized Representative's name]</i> Address: <i>[insert Authorized Representative's Address]</i> Telephone/Fax numbers: <i>[insert Authorized Representative's telephone/fax numbers]</i> Email Address: <i>[insert Authorized Representative's email address]</i>
07.	Attached are copies of original documents of: Articles of Incorporation or Registration of firm named in 1, above.

Signature of Bidder _____

Name _____

Business Address _____

MANUFACTURERS' AUTHORIZATION FORM

[The Bidder shall require the Manufacturer to fill in this Form in accordance with the instructions indicated. This letter of authorization should be on the letterhead of the Manufacturer and should be signed by a person with the proper authority to sign documents that are binding on the Manufacturer.]

Date : *[insert date (as day, month and year) of Bid Submission]*

Tender No. : *[insert number from Invitation For Bids]*

To : *[insert complete name and address of Purchaser]*

WHEREAS

We *[insert complete name of Manufacturer]*, who are official manufacturers of *[insert type of goods manufactured]*, having factories at *[insert full address of Manufacturer's factories]*, do hereby authorize *[insert complete name of Bidder]* to submit a bid the purpose of which is to provide the following Goods, manufactured by us *[insert name and or brief description of the Goods]*, and to subsequently negotiate and sign the Contract.

We hereby extend our full guarantee and warranty in accordance with Clause 2.20 of the General Conditions of Contract, with respect to the Goods offered by the above firm.

Signed: *[insert signature(s) of authorized representative(s) of the Manufacturer]*

Name: *[insert complete name(s) of authorized representative(s) of the Manufacturer]*

Title: *[insert title]*

Duly authorized to sign this Authorization on behalf of: *[insert complete name of Bidder]*

Dated on _____ day of _____, _____ *[insert date of signing]*

BID SECURITY FORM

Whereas _____
(hereinafter called the tenderer)

has submitted their offer dated _____
for the supply of _____
(hereinafter called the tender)

Against the Purchaser's Tender No. _____
KNOW ALL MEN by these presents that WE _____
of _____ having our registered office at
_____ are bound unto _____ (hereinafter called the "Purchaser")

In the sum of _____

For which payment will and truly to be made to the said Purchaser, the Bank binds itself, its successors and assigns by these presents. Sealed with the Common Seal of the said Bank this _____ day of _____ 20____.

THE CONDITIONS OF THIS OBLIGATION ARE:

(1)	If the tenderer withdraws or amends or modifies or impairs or derogates from the Tender in any respect within the period of validity of this tender.
(2)	If the tenderer having been notified of the acceptance of his tender by the Purchaser during the period of its validity
(3)	If the tenderer fails to furnish the Performance Security for the due Performance of the contract.
(4)	Fails or refuses to accept/execute the contract.

We undertake to pay the Purchaser up to the above amount upon receipt of its first written demand, without the Purchaser having to substantiate its demand, provided that in its demand the Purchaser will note that the amount claimed by it is due to it owing to the occurrence of one or both the two conditions, specifying the occurred condition or conditions.

This guarantee will remain in force up to and including 45 days after the period of tender validity and any demand in respect thereof should reach the Bank not later than the above date.

(Signature of the authorized officer of the Bank)

Name and designation of the officer
Seal, name & address of the Bank and address of the Branch

Note: Whenever the bidder chooses to submit the Bid Security in the form of Bank Guarantee, then he should advise the banker issuing the Bank Guarantee to immediately send by Registered Post (A.D.) an unstamped duplicate copy of the Guarantee directly to the Purchaser with a covering letter to compare with the original BG for the correctness, genuineness, etc.

PERFORMANCE STATEMENT FORM

Details of similar equipment / systems supplied & installed during past 3 years in India & Abroad

Name of the Firm _____

Order Placed by (full address of Purchaser)	Order No. and date	Description and quantity of ordered equipment	Value of order	Date of completion of deliver as per contract	Date of actual completion of delivery	Remarks indicating reasons for late delivery, if any	Has the equipment been installed/ working satisfactory? (Attach a certificate from the purchaser / Consignee)	Name of Contact person along with Telephone No., Fax No. and e-mail address

Signature and Seal of the manufacturer/Bidder

Place :

Date :

DEVIATION STATEMENT FORM**PART -I**

The following are the particulars of deviations from the requirements of the tender specifications:

CLAUSE	DEVIATION	REMARKS (INCLUDING JUSTIFICATION)

Place:

Date:

Signature and seal of the
Manufacturer/Bidder

NOTE:

Where there is no deviation, the statement should be returned duly signed with an endorsement indicating "No Deviations".

PART – II
(Refer Clause 1.25 of Tender Document)

Sr. No.	TENDER REQUIREMENT	COMPLIANCE	Document Submitted
1	Bid is Signed	Yes / No	Yes / NA
3	Bid Validity (180 days after the date of Bid opening)	Yes / No Bid valid up to	Yes / NA
4	Warranty:	Yes / No	Yes / NA
5	Agree to submit Performance Security 10% of PO Value as per Clause 2.12.1 & as specified in SCC	Yes / No	Yes / NA
6	Original Equipment Manufacturer/Authorised Indian Agent agree to submit Contract Agreement in the form as per Chapter-7 (For procurement above Rs.25 Lakh)	Yes / No	Yes / NA
7	Original Equipment Manufacturer/Authorised Indian Agent agree to submit Indemnity Bond as per Chapter-8 & Annexure-J (For procurement above Rs.25 Lakh)	Yes / No	Yes / NA

The Bidder should submit other documents such as fulfillment of financial qualification criteria, Schedule of Requirement (Chapter-3) and various forms as specified in Chapter-8.

SERVICE SUPPORT DETAIL FORM

Sr. No.	List of similar type of equipments serviced in the past 3 years	Address, Telephone Nos., Fax No. and e-mail address of the buyer	Nature of training Imparted/ service provided	Name and address of service provider

Signature and Seal of the manufacturer/Bidder.....

Place :

Date :

Bid Form

[The Bidder shall fill in this Form in accordance with the instructions indicated No alterations to its format shall be permitted and no substitutions shall be accepted.]

Date : *[insert date (as day, month and year) of Bid Submission]*

Tender No. :

To : Director, CSIR-NML, Jamshedpur

We, the undersigned, declare that:

(a)	We have examined and have no reservations to the Bidding Documents, including Addenda No.: <i>[insert the number and issuing date of each Addenda]</i>
(b)	We offer to supply in conformity with the Bidding Documents and in accordance with the Delivery Schedules specified in the Schedule of Requirements the following Goods and Related Services <i>[insert a brief description of the Goods and Related Services]</i> as specified in Chapter 4
(c)	The total price of our Bid, excluding any discounts offered in item (d) below, is: <i>[insert the total bid price in words and figures, indicating the various amounts and the respective currencies]</i>
(d)	The discounts offered and the methodologies for their application are: Discounts. If our bid is accepted, the following discounts shall apply. <i>[Specify in detail each discount offered and the specific item of the Schedule of Requirements to which it applies.]</i>
(e)	Our bid shall be valid for the period of time specified in ITB Clause 1.16, from the date fixed for the bid submission due date in accordance with ITB Clause 1.19 and it shall remain binding upon us and may be accepted at any time before the expiration of that period
(f)	If our bid is accepted, we commit to obtain a performance security in accordance with ITB Clause 1.41 and GCC Clause 2.12 for the due performance of the Contract
(g)	The following commissions, gratuities, or fees have been paid or are to be paid with respect to the bidding process or execution of the Contract: <i>[insert complete name of each Recipient, its full address, the reason for which each commission or gratuity was paid and the amount and currency of each such commission or gratuity]</i>

Name of Recipient	Address	Reason	Amount
_____	_____	_____	_____
_____	_____	_____	_____
_____	_____	_____	_____

(If none has been paid or is to be paid, indicate "none.")

(h)	We understand that this bid, together with your written acceptance thereof included in your notification of award, shall constitute a binding contract between us, until a formal contract is prepared and executed.
(i)	We understand that you are not bound to accept the lowest evaluated bid or any other bid that you may receive.

Signed : *[insert signature of person whose name and capacity are shown]*

In the capacity of *[insert legal capacity of person signing the Bid Submission Form]*

Name : *[insert complete name of person signing the Bid Submission Form]*

Duly authorized to sign the bid for and on behalf of: *[insert complete name of Bidder]*

Dated on _____ day of _____, _____ *[insert date of signing]*

PERFORMANCE SECURITY FORM

MODEL BANK GUARANTEE FORMAT FOR PERFORMANCE SECURITY

To,

.....

WHEREAS

(name and address of the supplier) (hereinafter called "the supplier") has undertaken, in pursuance of contract no. datedto supply (description of goods and services) (herein after called "the contract").

AND WHEREAS it has been stipulated by you in the said contract that the supplier shall furnish you with a bank guarantee by a scheduled commercial bank recognized by you for the sum specified therein as security for compliance with its obligations in accordance with the contract;

AND WHEREAS we have agreed to give the supplier such a bank guarantee;

NOW THEREFORE we hereby affirm that we are guarantors and responsible to you, on behalf of the supplier, up to a total of (amount of the guarantee in words and figures), and we undertake to pay you, upon your first written demand declaring the supplier to be in default under the contract and without cavil or argument, any sum or sums within the limits of (amount of guarantee) as aforesaid, without your needing to prove or to show grounds or reasons for your demand or the sum specified therein.

We hereby waive the necessity of your demanding the said debt from the supplier before presenting us with the demand.

We further agree that no change or addition to or other modification of the terms of the contract to be performed there under or of any of the contract documents which may be made between you and the supplier shall in any way release us from any liability under this guarantee and we hereby waive notice of any such change, addition or modification.

This guarantee shall be valid until the day of, 20.....

(Signature of the authorized officer of the Bank)

.....
Name and designation of the officer

.....
Seal, name & address of the Bank and address of the Branch

Note: Whenever, the bidder chooses to submit the Performance Security in the form of Bank Guarantee, then he should advise the banker issuing the Bank Guarantee to immediately send by Registered Post (A.D.) an unstamped duplicate copy of the Guarantee directly to the Purchaser with a covering letter to compare with the original BG for the correctness, genuineness, etc.

Acceptance certificate form

No.

Dated:

M/s. _____

_____**Sub: Certificate of commissioning of equipment**

01. This is to certify that the equipment as detailed below has/have been received in good condition along with all the standard and special accessories (subject to remarks in Para 2). The same has been installed and commissioned.

(a)	Contract No. Date:	
(b)	Description of the equipment	
(c)	Name of the consignee	
(d)	Scheduled date of delivery of the consignment to the Laboratory / Institutes	
(e)	Actual date of receipt of consignment by the Laboratory / Institutes	
(f)	Scheduled date for completion of installation/commissioning	
(g)	Actual date of completion of installation/commissioning	
(h)	Penalty for late delivery (at Laboratory / Institutes level) Rs.	
(i)	Penalty for late installation (at Laboratory / Institutes level) Rs.	

02 Details of accessories/items not yet supplied and recoveries to be made on that account:

Sr. No.	Description	Amount to be recovered

03 The acceptance test has been done to our entire satisfaction. The supplier has fulfilled his contractual obligations satisfactorily

OR

The supplier has **failed to fulfil** his contractual obligations with regard to the following:

Sr. No.	Failure	Amount to be recovered
(a)		
(b)		
(c)		

The amount of recovery on account of failure of the supplier to meet his contractual obligations is as indicated at para 03.

For Supplier

Signature

Name

Designation

Name of the firm.....

Date

For Purchaser

Signature

Name

Designation

Name of the Laboratory / Institute

Date

INDEMNITY BOND

No. _____

Date:_____

1) Amalgamation/Acquisition

In the event of M/s_____proposes for amalgamation, acquisition or sale of its business to any other firm during this contract period, M/s._____ and proposed Buyer/Successor of the Principal Company are liable to execute, fulfill contractual obligations without any deviations. For this purpose M/s. _____/M/s _____and proposed Buyer/Successor of the Principal Company shall indemnify itself to the Director, National Metallurgical Laboratories, Jamshedpur to fulfill the contractual obligations as per the terms of the CSIR-NML Global Tender and quotation of M/s. _____No. _____ dated_____

and National Metallurgical Laboratories P.O. No._____dated_____. The contractual obligations are supply, installation, commissioning, warranty maintenance/replacement of spares, accessories etc. as per the above mentioned Purchase Order.

2) Joint Venture, Consortium or Association

If the Supplier is a joint venture, consortium, or association, all the parties shall be jointly and severally liable to the CSIR-NML for the fulfillment of the provisions of the Contract and shall designate one party to act as a leader with authority to bind the joint venture, consortium, or association. The composition or the constitution of the joint venture, consortium, or association shall not be altered without the prior consent of the CSIR-NML.

3) Patent Indemnity

The Supplier shall, subject to CSIR-NML's compliance and indemnify and hold CSIR-NML and its employees and officers harmless from and against any and all suits, actions or administrative proceedings, claims, demands, losses, damages, costs, and expenses of any nature, including attorney's fees and expenses, which CSIR-NML may suffer as a result of any infringement or alleged infringement of any patent, utility model, registered design, trademark, copyright, or other intellectual property right registered or otherwise existing at the date of the Contract by reason of: (a) the installation of the Goods by the Supplier or the use of the Goods in India; and (b) the sale in any country of the products produced by the Goods.

For M/s._____
Principal Supplier.

For M/s _____
Indian Agent.

Eligibility Certificate

This is to certify that we are not associated, or have been associated in the past, directly or indirectly, with a firm or any of its affiliates which have been engaged by the Purchaser to provide consulting services for the preparation of the design, specifications, and other documents to be used for the procurement of the goods to be purchased under this Invitation of Bids / Tender No. _____ dated _____.

Authorised Signatory

Name: _____

Designation: _____

Non-Black listing Self Certificate

This is to certify that M/s. _____ has not been blacklisted by any Central / State Government Department / organization in last 3 years.

INTEGRITY PACT

Between

Council of Scientific & Industrial Research (CSIR) hereinafter referred to as “The Principal”.

And
.....herein referred to as “The Bidder/ Contractor.”

Preamble

The Principal intends to award, under laid down organizational procedures, contract/s forThe Principal values full compliance with all relevant laws of the land, rules, regulations, economic use of resources and of fairness/ transparency in its relations with its Bidder(s) and/or Contractor(s).

In order to achieve these goals, the Principal will appoint an Independent External Monitor (IEM), who will monitor the tender process and the execution of the contract for compliance with the principles mentioned above.

Section 1 – Commitments of the Principal

- (1) The Principal commits itself to take all measures necessary to prevent corruption and to observe the following principles:
 - (a) No employee of the Principal, personally or through family members, will in connection with the tender for, or the execution of a contract, demand, take a promise for or accept, for self or third person, any material or immaterial benefit which the person is not legally entitled to.
 - (b) The Principal will, during the tender process treat all Bidder(s) with equity and reason. The Principal will in particular, before and during the tender process, provide to all Bidder(s) the same information and will not provide to any Bidder(s) confidential/additional information through which the Bidder(s) could obtain an advantage in relation to the tender process or the contract execution.
 - (c) The Principal will exclude from the process all known prejudiced persons.
- (2) If the Principal obtains information on the conduct of any of its employees which is a criminal offence under the IPC/PC Act, or if there be a substantive suspicion in this regard, the Principal will inform the Chief Vigilance Officer and in addition can initiate disciplinary action.

Section 2 – Commitments of the Bidder(s)/Contractor(s)

- (1) The Bidder(s)/Contractor(s) commit himself to take all measures necessary to prevent corruption. He commits himself to observe the following principles during his participation in the tender process and during the contract execution.
 - (a) The Bidder(s)/Contractor(s) will not, directly or through any other Person or firm, offer, promise or give to any of the Principal’s employees involved in the tender process or the execution of the contract or to any third person any material or other benefit which he/she is not legally entitled to, in order to obtain in exchange any advantage of any kind whatsoever during the tender process or during the execution of the contract.
 - (b) The Bidder(s)/Contractor(s) will not enter with other Bidders into any Undisclosed agreement or understanding, whether formal or informal. This applies in particular to prices, specifications, Certifications, subsidiary contracts, submission or non-submission of bids or any other actions to restrict competitiveness or to introduce cartelization in the bidding process.
 - (c) The Bidder(s)/Contractor(s) will not commit any offence under the relevant IPC/PC Act; further the Bidder(s)/Contractor(s) will not use improperly, for purposes of competition or personal gain, or pass on to others, any information or document provided by the Principal as part of the business relationship, regarding plans, technical proposals and business details, including information contained or transmitted electronically.
 - (d) The Bidder(s)/Contractor(s) of foreign origin shall disclose the name and address of the

Agents/representatives in India, if any. Similarly the Bidder(s)/Contractor(s) of Indian Nationality shall furnish the name and address of the foreign principals, if any. Further details as mentioned in the “Guidelines on Indian Agents of Foreign Suppliers” shall be disclosed by the Bidder(s)/Contractor(s). Further, as mentioned in the Guidelines all the payments made to the Indian agent/representative have to be in Indian Rupees only. Copy of the “Guidelines on Indian Agents of Foreign Suppliers” is annexed and marked as Annexure.

- (e) The Bidder(s)/Contractor(s) will, when presenting his bid, disclose any and all payments he has made, is committed to or intends to make to agents, brokers or any other intermediaries in connection with the award of the contract.
- (2) The Bidder(s)/Contractor(s) will not instigate third persons to commit offences outlined above or be an accessory to such offences.

Section 3 – Disqualification from tender process and exclusion from future Contracts

If the Bidder(s)/Contractor(s), before award or during execution has committed a transgression through a violation of Section 2, above or in any other form such as to put his reliability or credibility in question, the Principal is entitled to disqualify the Bidder(s)/Contractor(s) from the tender process or take action as per the procedure mentioned in the “Guidelines on Banning of business dealings”. Copy of the “Guidelines on Banning of business dealings” is annexed and marked as Annex -“B”.

Section 4 – Compensation for Damages

- (1) If the Principal has disqualified the Bidder(s) from the tender process prior to the award according to Section 3, the Principal is entitled to demand and recover the damages equivalent to Earnest Money Deposit/ Bid Security.
- (2) If the Principal has terminated the contract according to Section 3, or if the Principal is entitled to terminate the contract according to Section 3, the Principal shall be entitled to demand and recover from the Contractor liquidated damages of the contract value or the amount equivalent to Performance Bank Guarantee.

Section 5 – Previous transgression

- (1) The Bidder declares that no previous transgressions occurred in the last 3 Years with any other Company in any country conforming to the anti corruption approach or with any other Public Sector Enterprise in India that could justify his exclusion from the tender process.
- (2) If the Bidder makes incorrect statement on this subject, he can be disqualified from the tender process or action can be taken as per the procedure mentioned in “Guidelines on Banning of business dealings.”

Section 6 – Equal treatment of all Bidders / Contractors/ Sub-contractors

- (1) The Bidder(s)/Contractor(s) undertake(s) to demand from all Subcontractors a commitment in conformity with this Integrity Pact, and to submit it to the Principal before contract signing.
- (2) The Principal will enter into agreements with identical conditions as this one with all Bidders, Contractors and Subcontractors.
- (3) The Principal will disqualify from the tender process all bidders who do not sign this Pact or violate its provisions.

Section 7 – Criminal charges against violating Bidders / Contractors/ Subcontractors

- (1) The Principal appoints competent and credible Independent External Monitor for this Pact. The task of the Monitor is to review independently and objectively, whether and to what extent the parties comply with the obligations under this agreement.
- (2) The Monitor is not subject to instructions by the representatives of the parties and performs his functions neutrally and independently. He reports to the JS(A), CSIR.
- (3) The Bidder(s)/Contractor(s) accepts that the Monitor has the right to access without restriction to all Project documentation of the Principal including that provided by the Contractor. The Contractor will also grant the Monitor, upon his request and demonstration of a valid interest, unrestricted and unconditional access to his project documentation. The same is applicable to Subcontractors. The Monitor is under contractual obligation to treat the information and documents of the Bidder(s) / Contractor(s) / Subcontractor(s) with confidentiality.
- (4) The Principal will provide to the Monitor sufficient information about all meetings among the parties related to the Project provided such meetings could have an impact on the contractual relations between the Principal and the Contractor. The parties offer to the Monitor the option to participate in such meetings.

- (5) As soon as the Monitor notice, or believes to notice, a violation of this agreement, he will so inform the Management of the Principal and request the Management to discontinue or take corrective action, or to take other relevant action. The monitor can in this regard submit non-binding recommendations. Beyond this, the Monitor has no right to demand from the parties that they act in a specific manner, refrain from action or tolerate action.
- (6) The Monitor will submit a written report to the JS(A), CSIR within 8 to 10 weeks from the date of reference or intimation to him by the Principal and should the occasion arise, submit proposals for correcting problematic situations.
- (7) Monitor shall be entitled to compensation on the same terms as being extended to/provided to Independent Directors on the CSIR.
- (8) If the Monitor has reported to the JS(A),CSIR, a substantiated suspicion of an offence under relevant IPC/PC Act, and the JS(A), CSIR has not, within the reasonable time taken visible action to proceed against such offence or reported it to the Chief Vigilance Officer, the Monitor may also transmit this information directly to the Central Vigilance Commissioner.
- (9) The word 'Monitor' would include both singular and plural.

Section 9 – Pact Duration

This Pact begins when both parties have legally signed it. It expires for the Contractor 10 months after the last payment under the contract, and for all other Bidders 6 months after the contract has been awarded.

If any claim is made/lodged during this time, the same shall be binding and continue to be valid despite the lapse of this pact as specified above, unless it is discharged/determined by JS(A), CSIR.

Section 10 – Other provisions

- (1) This agreement is subject to Indian Law. Place of performance and Jurisdiction is the Registered Office of the Principal, i.e. New Delhi
- (2) Changes and supplements as well as termination notices need to be made in writing. Side agreements have not been made.
- (3) If the Contractor is a partnership or a consortium, this agreement must be signed by all partners or consortium members.
- (4) Should one or several provisions of this agreement turn out to be invalid, the remainder of this agreement remains valid. In this case, the parties will strive to come to an agreement to their original intentions.

 (For & On behalf of the Principal)
 (Office Seal) (Office Seal)
 Place.....

 (For & On behalf of Bidder/Contractor)

..
 Date.....

Witness 1:
 (Name & Address): _____

Witness 2:
 (Name & Address): _____

Signature Not Verified

Digitally signed by ANAND BHARTI
 Date: 2018.06.11 17:46:55 IST
 Location: eProcurement System for
 Central PSUs

